

μ Angelo: A Novel Minimally Invasive Surgical System Based on an Anthropomorphic Design*

Antonia Tzemanaki^{1,2}, Thomas M. W. Burton¹, David Gillatt³, Chris Melhuish¹, Raj Persad³,
Anthony G. Pipe^{1,2}, and Sanja Dogramadzi^{1,2}

Abstract—Abdominal surgery has seen a rapid transition from open procedures to Robot-Assisted Minimally Invasive Surgery (R-A MIS). The learning process for new surgeons is long compared to open surgery, and the desired dexterity cannot always be achieved using the current surgical instruments. Furthermore, the way that these instruments are controlled plays an important role in their effectiveness and the ergonomics of the procedure. This paper presents the μ Angelo Surgical System for R-A abdominal MIS, based on an anthropomorphic design comprising two three-digit surgical instruments and a sensory hand exoskeleton. The operation of these subsystems and the efficacy of their corresponding performance are demonstrated.

I. INTRODUCTION

Robot-Assisted Minimally Invasive Surgical (RA-MIS) systems require two main components: the robotic cart with slender instruments that can be inserted into the patient's abdomen for carrying out the surgical tasks, and a surgical interface to control the instruments. In order to improve the patient's safety and the surgeon's efficiency and experience, great efforts are being put into designing new MIS instruments and systems. The current state of the art, the Da Vinci Surgical System [1], carries a gripper attached to a three Degree-of-Freedom (DOF) wrist. Other designs include continuum surgical robots such as [2] and [3]; despite their many DOF, the surgeon will have to be thoroughly trained to operate these systems. Studies have shown that surgeons are not satisfied with the level of dexterity and ergonomics of the current instruments available for traditional laparoscopy or RA-MIS [4], [5]. The instruments' end-effector has limited DOF, while the manipulation of the instruments is complex, as their design is not similar to human hands. By reconsidering this design, issues of reduced dexterity and bad ergonomics can be addressed.

Two-digit grippers may be able to grasp objects firmly, however, they allow "manipulations to only be done by movements of the wrist and arm" [6]. The seven basic functions of the hand include precision pinch, opposition pinch, key pinch, chuck grip, hook grip, span grasp, and power grasp [7]. These functions, apart from power grasping, can be performed using the thumb, index and middle fingers. Furthermore, precision grips of small objects require only these three digits, while the ring and little fingers provide

extra stability [8]. Experiments with primates with opposable or pseudo-opposable thumbs showed that these three digits accounted for 86% of the observed "precision grips" [9].

In order to reduce the "cognitive gap" between the current manipulation of the RA-MIS instruments and the surgeon's natural hand movements, we have previously presented a concept for hand-like instruments, each carrying an articulated three-digit system that emulates the surgeon's fingers' movements [10]. A three-digit miniature hand was also developed in [11], where each unit is inserted individually through trocars into the abdomen and then assembled into a five DOF hand. However, as the assembly process requires two free trocars, this could be time consuming and difficult to achieve.

For accurate control of the robotic instruments, the highly dexterous motions of the surgeon's hand must be precisely detected. For an anthropomorphic based surgical end-effector, the most intuitive interface for surgeons to use is one that fits around their hand and allows control of the instrument as if it is simply an extension of their own body. Current devices for measuring hand position and joint angles are either based around flexible sensor technology or around rigid links with encoders for each joint [12]–[14]. In [15], a three-digit gripper with ten DOF is deployed in the patient's abdomen and controlled by a master glove carrying potentiometers. There are two principle problems with the above concepts. Flexible sensor data gloves are lightweight and can be cheap to manufacture, however, joint resolution is too low for surgical use as the sensors give a more generalized impression of a gesture rather than precise joint flexion angles (the error can be as great as 27° in [12], showing only intention of the user). Rigid joint mechanisms can give more precise joint flexion angles but can be heavy and restrictive to the operator's hand during prolonged use.

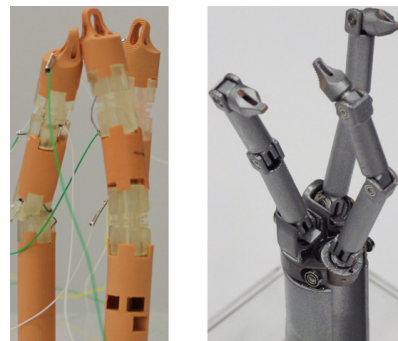

Fig. 1. Old and new design of the three-digit instrument prototype

*This work has been supported by the Bristol Urological Institute
antonia.tzemanaki@brl.ac.uk

¹Bristol Robotics Laboratory, T Block, Frenchay Campus, Bristol, UK

²Department of Engineering Design and Mathematics, University of the West of England, Bristol, UK

³Bristol Urological Institute, Southmead Hospital, Bristol, UK

We have reported our initial efforts in designing a hand exoskeleton to measure the joint angles of the surgeon's fingers in [16], where hall-effect sensors were used to detect joint flexion angles. The μ Angelo Surgical System constitutes the two subsystems of the anthropomorphic surgical instruments and the sensory exoskeleton [10], [16]. The potential of the concept was evaluated with surgeons through structured focus groups. They commended the concept for its intuitiveness and usability [5].

In order to allow a surgeon to use their hands in a natural way while obtaining a higher resolution joint flexion data, a new hand exoskeleton (Section III) with improved ergonomic design and motion capture precision has been developed. In parallel, following on from the design presented in [5], we have created a second prototype of the three-digit instrument comprising a cable-driven mechanism (Section II).

II. RA-MIS ANTHROPOMORPHIC INSTRUMENTS

The previous version of the instrument prototype (Fig. 1-left) involved operation of each joint using Shape Memory Alloy (SMA) helices. Although the SMA actuators allowed for both independent movement of each joint and miniaturization, the produced force was inadequate for surgical tasks.

The new prototype, also shown in Fig. 1 (right), has 14 DOF and carries a cable-driven mechanism, accommodated inside the digits and through the shaft supporting them. The three digits represent the thumb, index and middle fingers (Fig. 2d). In order to make the tool even more compact and to minimize the required incision, the thumb is initially inside the shaft and beneath the index and middle fingers (Fig. 2a), so that the overall diameter of the instrument is 18mm.

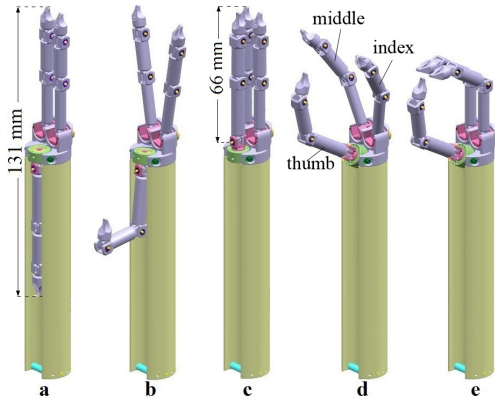

Fig. 2. Different positions of the instrument prototype

A. Surgical Concept

Fig. 3 depicts snapshots of a simulation of the surgical concept using the anthropomorphic instruments. The illustrated mesh represents the patient's abdomen. After the instruments enter the inflated abdominal cavity, the thumbs are carefully deployed. Then, the surgeon takes control and manipulates the digits. At the end of the surgery, the digits return to the initial configuration (Fig. 2a) and exit the abdominal cavity.

Different layouts of the instruments are shown in Fig. 2 in more detail; a) insertion (initial position), b) unfolding,

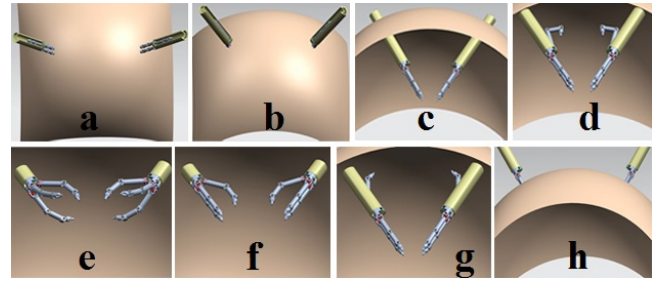

Fig. 3. Concept of surgery using the anthropomorphic instruments: a-c entering the abdomen, d) unfolding of the thumb, e-f manipulation by the surgeon, g) folding back the thumb, h) exiting the abdominal cavity

TABLE I
RANGE OF THE JOINTS OF THE INSTRUMENTS

Digits	Type of joint	DOF	Range (degrees)
Index and middle	DIP	1	[0, 90]
	PIP	1	[0, 90]
	MCP	2	[-27, 27]
Thumb	IP	1	[0, 90]
	MCP	1	[0, 90]
	CMC	3	[-180, 0] [55, 125] [-20, 20]

DIP: Distal Interphalangeal, PIP: Proximal Interphalangeal, MCP: Metacarpophalangeal, IP: Interphalangeal, CMC: Carpometacarpal

d) manipulation and e) grasping. The greatest distance of the compacted thumb from its base during the unfolding sequence is 42 mm (Fig. 4) and hence, the risk of injury of surrounding tissues in an inflated abdominal cavity is minimal. The extended length of the instrument during insertion is 131 mm (the thumb is folded at this time - Fig. 2a) and 66 mm when the thumb is unfolded (Fig. 2c). Table I summarizes the chosen angle range of the different joints of the instrument. An experiment with ten participants showed that the opening between their index and middle fingers was never greater than 54° and hence, the range for the MCP (abduction) joint was chosen to be $[-27^\circ, 27^\circ]$. Although the combined workspace of the three digits of the instrument is complex, it is possible to estimate the maximum workspace of the instrument during surgical tasks as the $3/4$ of a 66 mm radius sphere (Fig. 4).

Lifting a large and heavy organ, such as the liver, by pinching it with a small gripper could result in dangerous haemorrhage. Therefore, a compromise between the miniaturization of the instrument and the ability to grasp organs of a larger diameter without traumatizing them is needed [5]; each digit has a length of 66 mm (about half the length of an average human finger). Nevertheless, for when precision grasping is required, the digits are miniaturized to such an extent that the last link (7 mm length of grasping surface) of each digit has a similar size to the end-effector of standard surgical forceps (Da Vinci: needle drivers - 5 mm, Maryland forceps - 11 mm, prograsp forceps - 14 mm).

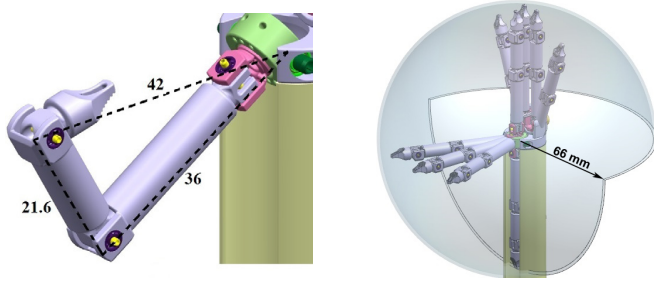

Fig. 4. Workspace of the instrument during insertion and operation (dimensions in mm and measured to the edge of each body)

B. Design of Digits and Mechanism

The computer-aided drawings and the dimensions of the various components are shown in Fig. 5 (index and middle fingers are identical). As in [5], the texture of the last links of the digits resemble laparoscopic forceps when combined (combinations of thumb-index and thumb-middle finger) for a more efficient grasp. The digits were fabricated using 3D printing in a rigid, high temperature-resistant resin (Nano-Cure, Envisiontec, Germany).

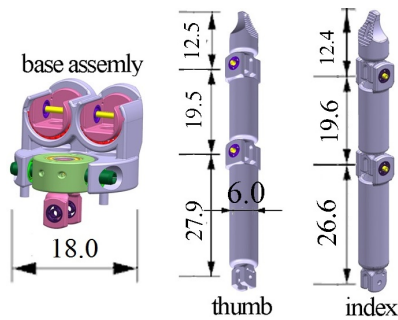

Fig. 5. Computer-aided design of the instrument's parts (dimensions in mm)

The DIP and PIP joints (see Table I) of the index and middle fingers, as well as the thumb's IP and MCP, are rotary joints with one DOF each. Fig. 6 depicts the mechanism of a single DOF joint connecting the last and the middle link of a digit via two bearings and a shaft. Each DOF is controlled by two cables (high performance polyethylene fiber, 0.12 mm diameter) attached to one of the links. The MCP joints of the index and middle fingers have two DOF (flexion and abduction) and thus, each joint is controlled by two cables acting in two vertical directions. Similarly, the three DOF of the thumb's CMC joint are controlled by three cables.

One end of each cable is connected to a spring which applies a constant tension to the cable and keeps the joint at 0° , while the other end is attached via a pulley (12 mm diameter) to the shaft of a motor. The motors and springs are located outside of the instrument. Fig. 7 shows the testing of the DIP and PIP joints of one digit, using two servo-motors (1.02 Nm maximum torque) and springs with a constant of 530 N/m.

C. Digit Force

In order to evaluate and compare this design with the one in [5], a similar method of force measurement was used. A

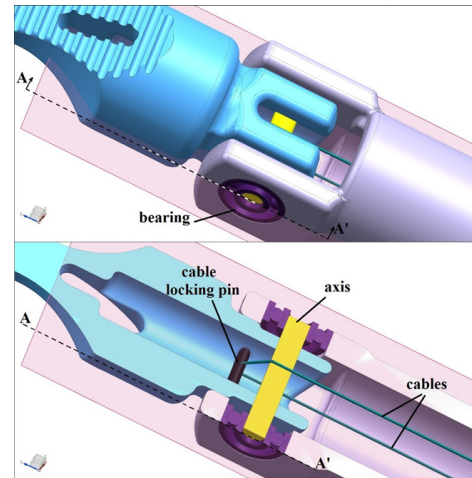

Fig. 6. a) 3d aspect b) cross section of one DOF joint

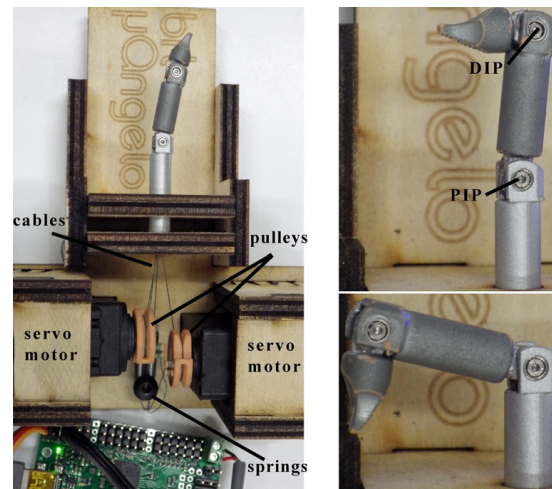

Fig. 7. Testing one digit of the instrument using two servo-motors

pressure sensor (FS01, Honeywell, USA) with a 3D printed hemisphere attached on top and a sensing range of 0-6.5 N was used while the DIP and PIP joints of one digit were active. The maximum measured force was 3 N (mean of 10 tests with $\sigma=0.1$), exceeding the 0.18 N measured in [5]. It is also within the 2-9 N range of required forces when pulling tissue as determined in [17].



Fig. 8. Testing the maximum applied force

III. SURGEON'S INTERFACE

A. Design Criteria

As part of the design process for a new hand exoskeleton a number of requirement criteria were prioritized to make a

device suitable for robotic surgery. Namely, the exoskeleton must:

- Accurately obtain joint angles during digit flexion and abduction/adduction for precision control of robotic devices,
- Be lightweight to prevent fatigue during extended periods of operation,
- Not impede normal motion of the hand so that the surgeon has full dexterity during operations and
- Fit a large range of hand sizes so that a single device is not limited to a single surgeon.

Furthermore, having the ability to provide haptic feedback to the surgeon could vastly help with tasks requiring highly dexterous manipulation of tissues within the body [18] (Section III-C).

The new design was based around previous work on hand exoskeletons presented in [19]. The new exoskeleton was designed to comfortably fit around the 5th to 95th percentile of hand lengths and breadths (5th percentile - 173 mm and 78mm respectively and 95th percentile - 205 mm and 95 mm respectively) as described in [20]. The equations of [21] were then used to estimate the maximum and minimum required length for the index, middle and thumb digit lengths (only the first three digits were used to control the robot manipulator). Designing the mechanism's digit lengths using these equations means that the device is able to have its joint axes aligned with the natural joint axes of the surgeon as in [19]. Furthermore, it allows for the hall-effect sensors (Melexis 1D and 3D rotational sensors) to be accurately positioned so that the correct joint angle is measured (1 mm distance from the magnet and 0.5 mm offset from the joint axis). This is a very important aspect of the design as it means the device is comfortable to wear for the surgeon while allowing for accurate information about the joint position to be extracted.

The exoskeleton weighs 154 gr and is scalable to the range of hand sizes listed above via lead screws embedded into the mechanism, allowing each segment length of a digit to be elongated or contracted to suit an individual's anatomy (Fig. 9). Adjustment is achieved via a hex key inserted into each segment to turn the screw.

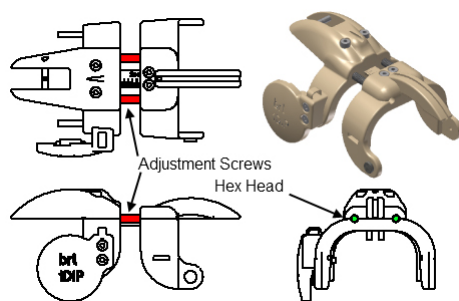

Fig. 9. The adjustment mechanism for increasing or decreasing mechanism segment lengths to fit different sized hands

B. Operation of the Exoskeleton

The DIP and PIP joints of the index and middle finger and the IP of the thumb use the 1-DOF Melexis hall-effect

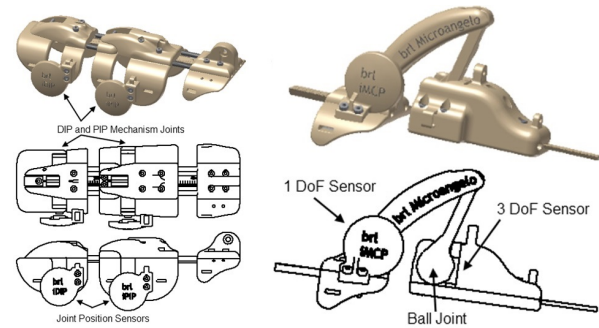

Fig. 10. The DIP and PIP mechanisms (left) and the MCP mechanism joint with a ball joint (right)

sensors to detect angular rotation of the joint. The joints of each segment operate around miniature bearings placed either side of the joint to reduce friction. Use of the lead screw adjustment mechanism allows for the bearings to be positioned with their axes aligned with the joint's natural axis of rotation. The mechanisms and sensors for these joints are shown in Fig. 10 (left).

However, the MCP joints of the fingers and thumb require more complex mechanisms to track their respective motions. For the index and middle MCP joints a ball and socket mechanism along with a 3-DOF Melexis hall-effect sensor were used, combined with a 1-DOF Melexis sensor for the redundant link joint, to obtain MCP flexion/extension and abduction/adduction angles. The mechanism for this can be seen in Fig. 10 (right).

The MCP joint of the thumb is a highly intricate and complex mechanism. The device developed here used a similar mechanism to that used for the finger MCP joints in that a ball joint was used to allow for flexion/extension and abduction/adduction of the thumb with a 3-DOF Melexis sensor and a 1-DOF Melexis sensor for the redundant link. However, unlike the fingers, the thumb has much larger segment lengths between the ball joint on the hand plate and the IP mechanisms. To ensure correct movement of the ball joint, an additional unconstrained four-bar mechanism was added to the design as shown in Fig. 11.

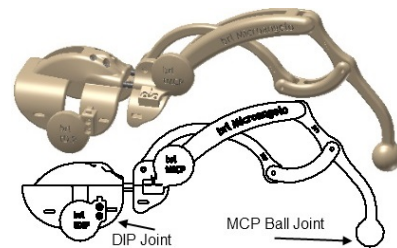

Fig. 11. Thumb MCP joint mechanism showing ball joint and four bar mechanism

All of the electronics were grounded onto a plate mounted on the dorsal side of the hand. Digits were constrained to the device via soft and flexible straps to ensure a snug fit for correct operation as shown in Fig. 12. As an additional safety feature, each of the sensors was equipped with an LED

to indicate power as shown in Fig. 12. This would provide the surgeon with a very clear indication that there was a problem should one of the sensors fail allowing them to halt the procedure to prevent any possible injury to the patient. The full design in different digit configurations can be seen in Fig. 13, which demonstrates its high digit maneuverability during dexterous tasks.

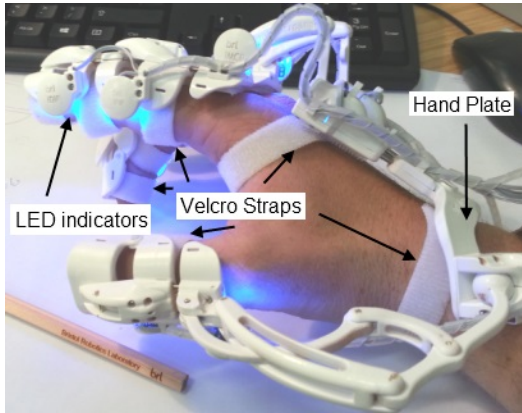

Fig. 12. Mechanisms attached to hand plate. Also shown are the LED indicators and the straps to hold the mechanism to the hand

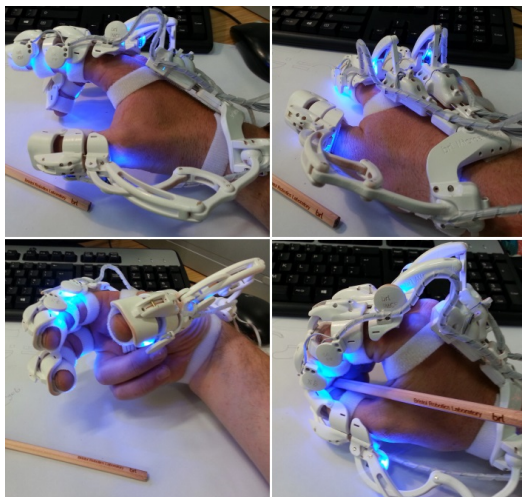

Fig. 13. The Exoskeleton in a number of different digit configurations

C. Suitability for Haptic Feedback

As mentioned in section III-A, an important aspect of a robotic surgical system is the ability to provide haptic feedback during operations. While not currently implemented, the design is based around the work of [19], in which similar mechanisms were actuated to provide motion to a stroke patient during therapy. Using an open-pulley design with the center of rotation coincident to the joint's axis, forces can be applied to each individual phalanx via a cable drive system as shown in Fig. 14; this can in turn be used to provide feedback to the surgeon during operations.

Force applied to the cable at “i” around the guide at “ii” produces a force on the digit around the joint at “iii” via the

“open-pulley”. This could also be used to provide a resistive force to the surgeon as they flex their digit to achieve a level of force feedback.

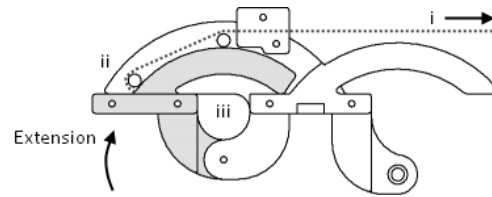

Fig. 14. Force feedback module

IV. REMOTE CONTROL

The exoskeleton was connected via RS-232 to a virtual model (MATLAB). Fig. 15 illustrates parts of the simulation of the DIP and PIP joints of the user's middle finger. The visualization of the user's motions was successful, setting the initial grounds for a surgical simulation environment. However, additional efforts are required to address the response delays due to software and manufacturing issues.

Fig. 16 shows a similar experiment where the user of the exoskeleton controls the one-digit structure of section II-B. The data were also transmitted by RS-232 to the motors, however it is also possible to transmit the data over internet protocol.

V. CONCLUSIONS

μ Angelo is a novel surgical system where the surgeon controls anthropomorphic instruments by wearing a lightweight sensory exoskeleton. The design aims at high dexterity and precision during surgical tasks, while the length of training of new surgeons could be shortened due to its ease of use.

The exoskeleton is adjustable to most digit lengths and the next iteration of this design will be scalable also for a range of different digit diameters. The current size of the tele-operated system and its intricate design fit the aforementioned surgical requirements in terms of ergonomics and precision. Additionally, the measured forces are promising and comparable with the required reference forces reported in the literature.

A very important attribute of a surgical system is its precision and perfect communication between the instruments and the surgeon's interface. Further analysis and specification of both sides of the system is required. The accuracy of the exoskeleton's sensors and further tests of the tracking accuracy between the instrument and the exoskeleton comprise ongoing work. Future work will also demonstrate movements and control of all instrument joints and produce a detailed mapping of the exoskeleton's kinematics to those of the instrument.

Finally, although 3D printing is a cheap and fast manufacturing method, the resolution and minimum wall thickness of the parts is limited, making any further miniaturization of the instrument prototype difficult. Other, more expensive methods, such as metal laser sintering in bio-compatible

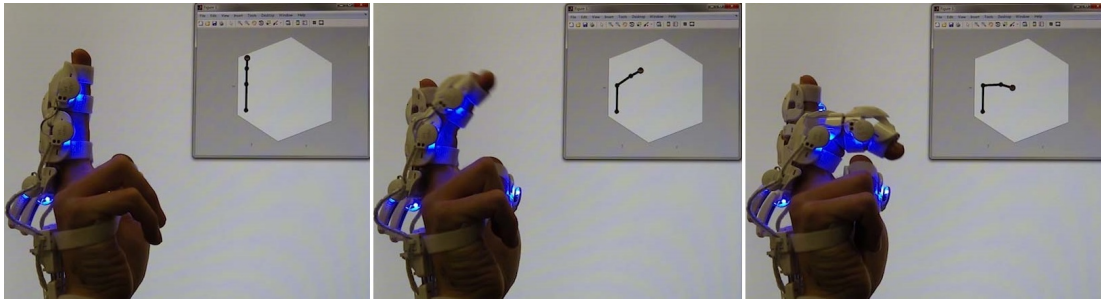

Fig. 15. The user wears the exoskeleton and controls a virtual model of his middle finger

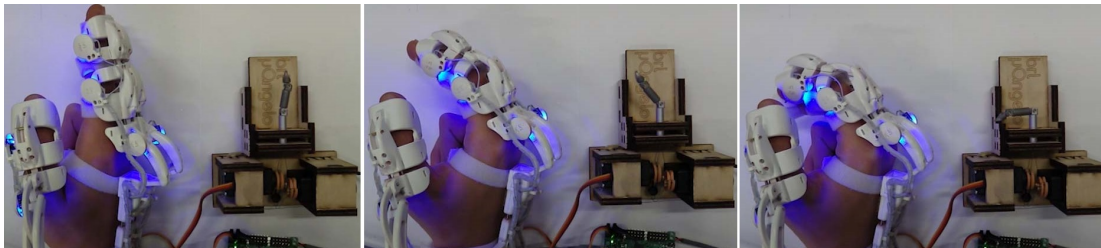

Fig. 16. Controlling one digit of the instrument using the exoskeleton

materials, can achieve the required dimensions of the final product.

ACKNOWLEDGMENTS

A.T. thanks Mr Charles F. Nevett for his help and cooperation.

REFERENCES

- [1] "Da vinci surgery - robotic-assisted minimally invasive surgery." [Online]. Available: www.davincisurgery.com/da-vinci-surgery/
- [2] K. Xu and X. Zheng, "Configuration comparison for surgical robotic systems using a single access port and continuum mechanisms," in *IEEE International Conference on Robotics and Automation*, 2012.
- [3] M. Niccolini, G. Petroni, A. Menciassi, and P. Dario, "Real-time control architecture of a novel single-port laparoscopy bimanual robot (sprint)," in *IEEE International Conference on Robotics and Automation*, 2012, pp. 3395–3400.
- [4] K. Done, A. DiMartino, T. Judkins, S. Hallbeck, and D. Oleynikov, "Evaluation of laparoscopic tools for usability and comfort," *Proceedings of the Human Factors and Ergonomics Society Annual Meeting*, vol. 48, no. 12, pp. 1359–1362, 2004.
- [5] A. Tzemanaki, P. Walters, A. G. Pipe, C. Melhuish, and S. Dogramadzi, "An anthropomorphic design for a minimally invasive surgical system based on a survey of surgical technologies, techniques and training," *The International Journal of Medical Robotics and Computer Assisted Surgery*, 2013.
- [6] T. Iberall, "The nature of human prehension: Three dextrous hands in one," in *Robotics and Automation. Proceedings. 1987 IEEE International Conference on*, vol. 4, Mar 1987, pp. 396–401.
- [7] S. W. Wolfe, R. N. Hotchkiss, W. C. Pederson, and S. H. Kozin, "Goals of Treatment; Biomechanics of the Injured Hand," in *Greens Operative Hand Surgery*, 6th ed. Elsevier, 2010.
- [8] J. R. Napier, "The Prehensile Movements of the Human Hand," *Journal of Bone & Joint Surgery, British Volume*, vol. 38-B, no. 4, pp. 902–913, 1956.
- [9] M. B. Costello and D. M. Fragaszy, "Prehension in Cebus and Saimiri: I. Grip type and hand preference," *American Journal of Primatology*, vol. 15, no. 3, pp. 235–245, 1988.
- [10] A. Tzemanaki, S. Dogramadzi, T. Pipe, and C. Melhuish, "Towards an anthropomorphic design of minimally invasive instrumentation for soft tissue robotic surgery," in *Advances in Autonomous Robotics*. Springer, 2012, pp. 455–456.
- [11] R. Ohshima, T. Takayama, T. Omata, T. Ohya, K. Kojima, K. Takase, and N. Tanaka, "Assemblable three fingered five-DOF hand for laparoscopic surgery," *2008 IEEE International Conference on Robotics and Automation*, pp. 3896–3901, May 2008.
- [12] M. Zecca, N. Endo, K. Itoh, K. Imanishi, M. Saito, N. Nanba, H. Takanobu, and A. Takanishi, "On the development of the bioinstrumentation system wb-1r for the evaluation of human-robot interaction - head and hands motion capture systems-," in *2007 IEEE/ASME international conference on Advanced intelligent mechatronics*, 2007, pp. 1–6.
- [13] Y. Kunii, Y. Nishino, T. Kitada, and H. Hashimoto, "Development of 20 dof glove type haptic interface device-sensor glove ii," in *IEEE/ASME International Conference on Advanced Intelligent Mechatronics '97*, 1997, pp. 132–137.
- [14] J. Blake and H. Gurocak, "Haptic glove with mr brakes for virtual reality," *IEEE/ASME Transactions on Mechatronics*, vol. 14, no. 5, pp. 606–615, 2009.
- [15] H. Luo and S. Wang, "Multi-manipulation with a Metamorphic Instrumental Hand for Robot-assisted Minimally Invasive Surgery," in *IEEE/ICME International Conference on Complex Medical Engineering*, Harbin, China, 2011, pp. 363–368.
- [16] A. Tzemanaki, X. Gao, A. G. Pipe, C. Melhuish, and S. Dogramadzi, "Hand exoskeleton for remote control of minimally invasive surgical anthropomorphic instrumentation," in *The 6th Hamlyn Symposium on Medical Robotics*, G.-Z. Yang and A. Darzi, Eds. Imperial College London, 2013, pp. 81–82. [Online]. Available: <http://ubimon.doc.ic.ac.uk/Hamlyn2013/public/Proceedings\2013\2.pdf>
- [17] A. J. Madhani, G. Niemeyer, and J. K. J. Salisbury, "The black falcon: a teleoperated surgical instrument for minimally invasive surgery," in *International Conference on Intelligent Robots and Systems*, vol. 2, no. October. IEEE, 1998, pp. 936–944.
- [18] O. Meijden and M. Schijven, "The value of haptic feedback in conventional and robot-assisted minimal invasive surgery and virtual reality training: a current review," *Surgical Endoscopy*, vol. 23, no. 6, pp. 1180–1190, 2009.
- [19] T. M. W. Burton, R. Vaidyanathan, S. Burgess, A. J. Turton, and C. Melhuish, "Development of a parametric kinematic model of the human hand and a novel robotic exoskeleton," in *2011 IEEE International Conference on Rehabilitation Robotics (ICORR)*, 2011.
- [20] S. Pheasant and C. Haslegrave, *Bodyspace: Anthropometry, Ergonomics, and the Design of Work*. Taylor & Francis, 2006. [Online]. Available: <http://books.google.co.uk/books?id=nwfvSbuyBdMC>
- [21] B. Buchholz, T. J. Armstrong, and S. A. Goldstein, "Anthropometric data for describing the kinematics of the human hand," *Ergonomics*, vol. 35, no. 3, pp. 261–273, 1992, PMID: 1572336.