

VT Position Code Communication Technology and Its Implementation

ShiYing Zhou

School of Computer Science and
Technology
Jilin University
Changchun, China
zhouzou39@tom.com

GuiHe Qin

School of Computer Science and
Technology
Jilin University
Changchun, China
qingh@jlu.edu.cn

YuBo Jin

School of Computer Science and
Technology
Changchun University of Science and
Technology
Changchun, China
jybsky@sohu.com

Abstract—A kind of new electronic communication technology is presented in this paper. The technology quantifies the time axis and the voltage axis synchronously, uses the quantified time dot as the address of the communication, and realizes the transmission of the multi-system [1] data via transmitting the multi-steps voltage quantification. This new technology can solve the bottleneck problem of the speed, circuit and electromagnetism in the electronic communication, change the binary system coding mode and communication connection form of the electronic device, debase the complexity of the devices connection, enhance the rate of the processing and the transmission, reduce the transmission quantity of the redundant information, simplify the transformation between the difference protocols. The single-lined system automobile controller [2] based on the second-step voltage quantification method of this technology has been verified in the actual application, and obtained the invocation patent. The experimental results approve the validity and the robustness of the technology.

Keywords—VT position code communication technology, multi-system data, communication connection

I. INTRODUCTION

With the development of the chip manufacturing, parallel processing, computer architecture, distribute technology, operating system, software application platform, network computing and intranet, the performances of computer have improved continuously and reached unprecedented height. However, all of above are based on computer hardware. Consequently, the organization of computer hardware has become the main problem in development of computer science. But the traditional theories about computer hardware have many defaults. First of all, the transmit speed is the “speed bottleneck” [3] of electron device. The communications between electronic devices are all electrical signals. Electron has become the way of digital signals transmission. Hence, the speed of electron can represent electrical signal’s transmission speed and it affects the electronic devices’ processing and communication speed directly. Since the electron transmit at a constant speed in the same metal, which will battle us producing chips with higher performances. Secondly, the number of wires becomes the

“wire bottleneck” [3] of the development of silicon chip. In order to improve the processing speed and capacity of chips, the computer designer must set up more wires for data transmission. With the development of semiconductor, the size of chips becomes much smaller. The main problem in chip manufacture is the outputting of pins [4], but the semiconductor’s processing. It is such a difficult thing to output pins from the small chips. Moreover, the connections between chips and circuit boards have their own limitations. There may be 1000 connections on each board, but for the reason of economizing the cost, the actual connections are much less than these limitations. Thirdly, the electromagnetism interference caused by the layout of wires on the circuit board has become the “electromagnetism bottleneck” [5] of the electronic circuitry. The electromagnetism interference between wires on the same board can affect the accuracy of signal transmission. Along with the elevation of the outputting pins and the complexity of circuit, the use and connections of wires are more and more. Consequently, the affection of electromagnetism interference may also be growing so as to affect signal transmission.

Aiming at the above situations, people are making many researches. The scientists are making researches on electronic signal transmission without wires. Now the WI-FI net [6] and mobile phone have been using the wireless transmitting technology. The principle of this method is shown as follows. First, the reversible electron can spin and this may cause a resonance. Secondly, magnetic field will make the electron deflexion and then correct their magnetic directions. Finally, the electron’s vibration will produce microwave energy. Therefore, we can use the microwave energy to transmit electron signal. And by this way, the electronic signal can not be weakened when transmitting on the wire. Although the wireless transmitting technology could avoid the weakening of the electron signal by wires, it can be affected by a lot of elements. For example, lighting and shielding may cause some problems. Wireless transmitting technology has poor electromagnetic compatibility and stability. And the signal transmission devices (magnetic field generator [7]) are so large that can not be embedded in chips.

Since the problems of the constant transmission speed and wire factors when electron transmitting in the metal, the researchers use photon technology [3], [8] instead of electronic technology. Photon transmission is a kind of wireless transmitting technology which transmits by air and its speed is ten times faster than electronic transmission in metal. And photon beams can not cross with each other and also can not affect each other, so photon beams can pass through two dimensions and three dimensions freely [9].

Although the photon chips [10] need not connect by fiber, but the devices which are used to guide the direction of light need to be allocated in order to realize the communications between chips. The chip will be full of laser generators on its surface. These laser generators will transmit the signal to laser receivers on another chip. After aligning two chips, photon can pass through the air and arrive at another chip. This kind of photon technology can improve the transmission speed and avoid the interference produced by wire, but the chip must be full of laser generators [11] and laser receivers [11]. Using this way we can cancel the output pins on chip, but we use laser generators and laser receivers instead. Consequently, we need more surfaces to allocate these devices. The information transmission amount of photon chip is determined by the amount of photon beams generated by the chip which means the amount of laser generators and laser receivers. With the size of chip smaller and smaller, its surface area also becomes limited. Therefore, the photon chip will face the bottleneck between the transmission runoff and the chip's volume too.

Although the technologies above can improve the situations that exist in electronic computer and communication network, they can not solve the essential problem of signal transmission. Computer and network have been ruled by the traditional BCD code(also called 8421 code). Because changing the transmission media (electron) is very difficult, the photon computer theory is very complexity, hard to realize, and it exists the quantity bottleneck of the laser generators and receivers, so it can not replace the electronic computer in short order.

The article advances a kind of new electronic communication coding protocol—VT position code communication technology [12], which alters the encoded mode and the communication manner, updates the communication theory of the electronic units. It essentially solves the problems that exist in the electronic computer and network.

II. THE THEORY OF THE VT POSITION CODE COMMUNICATION TECHNOLOGY

The VT position code communication technology quantifies the voltage signals of the V(voltage) axis based on the digital communication of binary system quantifies the T(Time) axis [13]; also may not quantify (using to complete the communication of the analog signals) [12]. Assuming, a one frame signal as the starting point, and defines the pulse on this point as the synchronous pulse. Figure 1 shows the communication coding pulse data chart of the VT position code.

The voltage axis expresses the voltage altitude of the pulse,

represents the data signal; and the time axis represents the relative position that each pulse relatives to the highest voltage, represents the address signal. We divide the pulse altitude into ten ranks, representing the number 0, 1, 2, 3, 4, 5, 6, 7, 8, 9, when need the number bigger than 10, we can choice two pulses to accomplish the transmission of this data, and the data that the former pulse represents is $10 \times (0, 1, 2, 3, 4, 5, 6, 7, 8, 9)$.

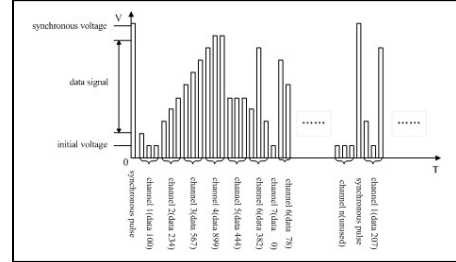

Figure 1. Communication coding pulse data chart of the VT position code

There are two types of data in the communication protocol of this coding technology: voltage data of the V axis and the time data of the T axis. Then we define the following parameter:

Dv : the initial voltage of coding, its definition is the smaller the better according to the electronic technics and the anti-jamming ability [14].

ΔV : the precision of the voltage quantification, its definition is the smaller the better according to the electronic technics, detecting and anti-jamming ability [14].

Mv : the highest signal coding voltage of the communication, its definition is the bigger the better according to the electronic technics [14].

ΔT : the time-based pulse width of coding, decided by the communication main frequency of the system.

T : the scanning time of one frame.

$Mv + \Delta V$: synchronizing pulse.

After the above definition, the model of the single-channel coding communication during the unitary medium has come into being: in the transmission system, the position of the signal that the sending element and the received element produced represents the address signal, the altitude of the signal pulse represents the data information of this signal, all elements can connect with each other by a communication line. The sending element emits the pulse signal with different voltage height in the different position, according to the practical demand, the address signal of each element may be one or more, if it's more, each address signal also represents the weighted signal of this element.

Using this method can realize the parallel communication between IC and computers with serial form, its communication speed is much higher than parallel. On the assumption that the same initial time T_0 , the data quantity of the computer serial

communication is $\frac{T}{\Delta T} \times N$, N is the information quantity of one frame; and our communication data quantity is

$\frac{T}{\Delta T} \times \frac{Mv - Dv}{\Delta V} \times N$. Not difficult to see, when quantifying the V axis, every time increasing the quantification rank will make the communication speed to enhance a time compared to the digital communication in the same situation, and the quantification rank is decided by the highest altitude of pulse Mv and the precision of the voltage quantification ΔV , the rank of these two quantity will be higher and higher along with the development of the VT position code technology. In addition, the T axis that we quantify during the communication indicates the communication address, thereby the address signal will not enter into the signal line, this characteristic will also decrease the transmission of the redundancy information, increase the communication speed. Thus, application of this coding communication fashion will increase the communication speed to an egregious multiple.

III. THE TECHNOLOGY FRAME OF VT POSITION CODE COMMUNICATION TECHNOLOGY

Figure 2 shows the developmental framework of the VT position code communication technology. The theory of VT position code communication technology creates the protocol and development platform; the encoder and decoder of VT position code communication technology can connect the control units and the execute units in the networked control system to realize the transfers of the control command; accession the module of digital data turn VT code and VT code turn digital data on the PLC will link PLC to the net of VT position code communication technology; then create the IC and CPU of VT position code communication technology; manufacture the VT position code computer and single chip; structure the network of VT position code communication technology.

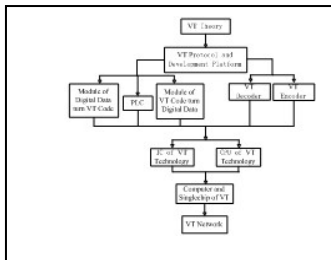

Figure 2. Developmental framework of the VT position code communication technology

A. The module of digital signal turn VT code and the module of VT code turn digital code

To make the controllers, executors and PLC to correspond with each other, we need to chip select except code transform. Namely using one net line to link the whole components together, thus all of the signals will concentrate on one signal line. This signal line connects with the module of VT code turn digital code that be loaded to PLC, chip selects and transforms the VT signal to digital signal, consequently to realize communicate with PLC. Moreover, the module of digital signal turn VT code signal that be loaded to PLC, transforms the execute signal sent out by PLC to VT code signal, and sends it to the signal line. Using this way, we will link PLC to the VT position code communication network. Also each executor can

be equipped with VT encoder and VT decoder, to realize the transform between the VT code signal and the digital signal, accordingly to achieve the mutual communicate among the controller, executor and PLC.

B. The Encoder and Decoder of VT Position Code Communication Technology

In the traditional industry applications, the controller connects with the executor via the wiring harness and implements control using the switch quantity, its connection is complex, its realizable function is limited and difficult to correct. At the present time, these redundancy wiring harness system are replaced by various fashions of the net connections, such as Ethernet [15], different buses (CAN bus [16]) and so on. But because of the demand of network protocol, one data packet need to transmit the information about address, checkout, data, thus the available control data quantity contained in a data package is rather finite, reducing the transmission efficiency. Otherwise, owing to the difference in the various industrial network protocol, we need to setup another gateway to transform the protocol format [17] when the executive machines using different network protocol want to correspond with each other. This pattern will increase both the number of the network equipments, network load and the transmission time delay.

Therefore, in order to predigest the connection means and to enhance the transmission efficiency, we need to transform the traditional connective manner and the control mode. The method which adopts here is using one net line to link the PLC and all controllers, executors together, the controller connects with the coder of VT position code—translating the control demand which sends out by the controller into the modality of VT position code; the executor connects with the decoder of VT position code—analyzing the received control demand; the output and input of PLC add the number to VT code module -realizing the transform between the binary code and VT position code. Figure 3 shows the connective structure of the VT position code communication technology network.

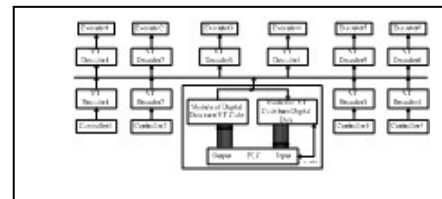

Figure 3. Diagram of VT position code communication technology network connections

The function of the coder is to code the control demand which sends out by the controller with VT position code format, then to transmit it based on the VT position code network protocol; the function of the decoder is to receive the signal of control demand from the net according to the rule of VT position code protocol, and to translate it to the control demand that can be identified by the executor. When initializing the system, we need to assign the fixed address to every executor, this address is used to identify the position that the instrument incepts the information (time point). Using this

method, the controllers and the executers on the VT position code network can realize the network transmission of the control demand founded on the VT position code principle. The principle diagram shows as follow.

C. CPU and IC of the VT Position Code Communication Technology

With the same principle of PLC chip select, applying the VT code to digital code module and the digital code to VT code module to manage the chip select signal and the data signal simultaneously, the VT logical [18] CPU and IC can be designed. Its hardware model is as follows shown in figure 4.

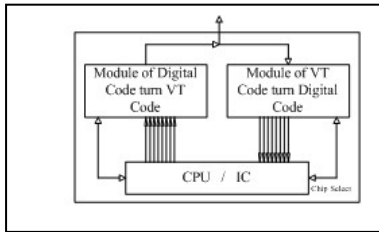

Figure 4. Hardware model of VT logical CPU and IC

The design model of this kind of logical CPU or IC can only satisfy the transmission of the simple data signal and a small quantity of address signal [19], when the equipments on the net increase, the control and feedback information that needed to be transmitted are becoming complex and various, it won't be suitable. The principle of VT position code communication technology requires that CPU is able to process the multi-system (exceed binary system) [20], therefore, in accordance with CPU/IC regular design method, the data line is responsible to transport the data information, the address line is used to transport the address information.

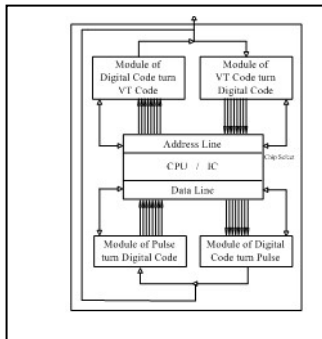

Figure 5. Hardware model of the multi-system CPU and IC

Figure 5 shows the hardware model of the multi-system CPU and IC [21]. Among them, the VT code to numerical code module and the numerical code to VT code module connected with the address line of CPU/IC, takes charge of the address message transmission and carries through the chip selection. And that the data line links with the digital code to pulse module and the pulse to digital code module, these two modules are devoted to transform the format between the pulse

voltage that transmits on the VT communication network and the data signal that can be processed by CPU /IC, to achieve mutual transmission of data information. Such a CPU/IC has the independent address and data information processing system, is able to dispose the multi-system, such as ternary [22], [23], quaternary [24] and so on.

D. The Computer and Single Chip of the VT Position Code Communication Technology

CPU is the core of the computer an single chip, after scheming out the CPU of VT position code, the structure of the VT position code computer can be designed according as the network connective principle. As illustrated in the figure 6, VT computer is linked by one single line —VT signal line [2], it's responsible for the transmission of all information in the whole computer system, the signal transmitted on it is pulse altitude signal. All components in the VT computer are connected to this VT signal line, the communication between them can be realized by the VT coder and VT decoder to transform the pulse signal and the data signal. These components send data messages to the VT signal line in the special time that system assigned to them, and receive the messages from the VT signal line in another special time. This kind of special time may be defined when system established, also may be redefined every time when system started (considering the system may add or subtract the equipments at any time).

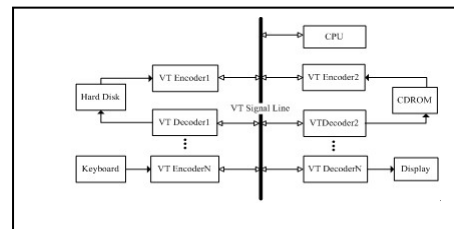

Figure 6. Structure of the VT position code computer

The single chip is a kind of micro computer system, its interior configuration is similar to the common computer, just simpler. Figure 7 shows the framework chart of VT single chip. As the system bus the VT signal line links all components, because each part of the single chip has been encapsulated already, the time spot that they send and receive message could be defined by analyzing during the initial period of system production, and be solidified in the system. VT CPU drives the concession and time circuit through the exterior time source [25], the internal and external interrupt signals [26] are both transformed to data signal by VT decoder, then send to CPU. The register, data memorizer, timer/counter, memorizer extended control port, parallel port and serial port [27] all send to and receive from the VT signal line via the VT coder/decoder. At the same time, the timer/counter [28] receives the external count signal through the VT decoder, the memorizer extended control port [29] send the control signal to the outside through the VT coder, the parallel and serial ports carry out the series-parallel input and output through the VT coder/decoder.

signal to the corresponding equipment on the special time, even if there's not the operation to this equipment in this period, system may also send the monitor signal to it to survey some parameters such as the current application state as the reference of the subsequent operation. Therefore, we can curtly consider the transmission ratio of effective data on VT network is 100%. According to the VT principle, this transmission ratio is invariable and doesn't change along with the increase of VT technology's step. Moreover, the channel utilization of VT network protocol is much higher than the TCP/IP, Ethernet [33], Fieldbus network [34], [35].

C. Future Work

The article describes the development configuration of the VT position code communication technology, and designs out the hardware model and schematics of its important parts. We take an experiment combining with the requirement of automobile body controller and two-step VT theory, the result confirms the validity and usability of the VT technology. Our research is only a preliminary exploration, the following work will be:

(1)We develop the VT technology from second-step to multi-step, and to realize the transmission of multi-system data. At the next stage, the experimental parameters will be presumed as follow, the initial voltage Dv is 2V, the precision of the voltage quantification ΔV is 1V, the synchronization voltage Mv is 12V. Here we define 2V (Dv) pulse signal as "0", define 3V pulse signal as "1", 4V pulse signal as "2" and so on. The main task during this period is designing the interior structure of multi-system CPU, computer and network.

(2)After the two-dimensional VT technology is mature, in order to improve the communication load and speed, the VT technology can be expanded to the three-dimensional that constituted by three axle ——V, I, T. The method will quantify the time signal on time axis, the voltage signal on V axis and the current signal on I axis simultaneously. In the coding course, three kind of different identifiers——V, I, T, are used to denote the data signal, address signal and status symbol.

Completion of the above work will form a set of integrated theory and application platform of VT position code communication technology, and this will lay the foundation for idiographic implementation.

V. CONCLUSIONS

In allusion to the various bottlenecks in the currently electronic communication, this article proposes a new coding method of electronic communication——VT position code communication technology. The method quantifies the coordinate vector of the two-dimensional space which constituted by time and voltage, uses time point as the communication address, and realizes the transmission of the multi-system data via transmitting the multi-steps voltage quantification. It has broken loose the fetter of the BCD thought completely. Using this method, all electronic components can communicate with each other through one signal line, avoid leading the IC, decrease the connection between devices and quantity of load switch, reduce the

connective complexity of the equipments. Besides, by being equipped with the VT coder and decoder, the electronic device can enter into the computer network and carry on correspond mutually. It may also simplify the data transmission format and protocol transform, improve the processing speed, reduce the transmission delay, enhance the utilization ratio of the system and network.

The VT position code communication technology can expend the versatility of equipments, simplify the structure and volume of them, reduce the production cost and the operating difficulty, networked the electronic devices. It can be widely applied to the electric control system, such as the automobile network, domestic electrical appliances network and office network. Through an accordant network protocol, all electronic devices will compose a uniform network system based on the single-lined connection, it has prominent practicability and efficiency. The design thought proposed in this paper advances a new kind of attempt and discussion for the innovation of the electronic communication form and network connective fashion.

REFERENCES

- [1] N. Guo, "An mary DS/SS communication system and the optimization of information-combination mapping," *Acta Electronica Sinica*, vol. 24, Apr. 1995, pp. 50-54.
- [2] G. Q. Wang, "The single-lined system automobile controller," *China. Patent ZL 01 0 48839.9*, July 23, 2001.
- [3] S. Z. Wang, "Photon computer is vividly portrayed," *Electron Science and Technology*, vol. 4, Jun. 2006, pp. 13-15.
- [4] J. Zhang, "Prospect for the development of the future computer and compute technology ," *Guangdong Science and Technology*, vol. 5, Oct. 2006, pp. 65-67.
- [5] X. C. Qi, "Analysis and Resolved Measures of Electromagnetic Interference Under Complicated Electromagnetic Environment," *Transaction of HuaBei Science and Technology Institute*, vol. 2, pp. 131-133, Jan. 2005.
- [6] L. B. Song, "Evaluating Next-Cell Predictors with Extensive Wi - Fi Mobility Data," *IEEE Transactions on Mobile Computing*, vol. 5, pp. 1633-1649, Dec. 2006.
- [7] D. Chieng, "QoS Performance Analysis of Multi-Radio Multi-Hop Wi-Fi Chain Network," in *2007 The 2nd International Conference on Wireless Broadband and Ultra Wideband Communications*, 2007, pp. 27-30.
- [8] Y. J. Zhao, "Look forward to the Future Development of the Computer," *Scutech Information Development & Economy*, vol. 15, July. 2005, pp. 21-23.
- [9] L. L. Hu, "Transmission performance of optical duobinary transmission system," *Acta Photonica Sinica*, vol. 32, June. 2003, pp. 727-730.
- [10] .X. W. Wang, "Research on intelligent virtual topology design methods in IP/DWDM optical internet," *Computer Engineer and Design*, vol. 26, Apr. 2005, pp. 847-849.
- [11] A. K. Datta, "Signed - negabinary - arithmetic -based optical computing by use of a single liquid - crystal -display panel," *Applied Optics*, vol. 41, Aug. 2002, pp. 1556-1564.
- [12] FAWER AUTOMOTIVE PARTS COMPANY LTD. PUMP BRANCH COMPANY, "Position code communication method and equipment thereof," *U.S. Patent 0 001 18*, Sep 16, 2005.
- [13] R. G. Lyons, "Digital Signal Processing," *New York*, 2006, pp. 23-54.
- [14] D. A. Weston, " Electromagnetic compatibility principle and application," *Canada*, 2006, pp. 196-221.
- [15] Z. Chao, "Research of 10-Gigabit Ethernet MAC," *Computer Engineering*, vol. 17, Sep. 2007, pp. 31-33.

- [16] H. Hansson, "Integrating reliability and timing analysis of CAN-based systems," *IEEE Trans. on Industrial Electronics*, vol. 6, pp. 1240-1250, Dec. 2002.
- [17] 3ae-2002 LAN/MAN Standards Committee of the IEEE Computer Society. Amendment: Media Access Control(MAC) Parameters, Physical Layers, and Management Parameters for 10 Gb/s Operation, IEEE Std. 802. 2002.
- [18] J. Zhang, "Design for 8-bit RISC CPU based on FPGA," *Microcomputer Information*, vol. 35, Dec. 2006, pp. 155-157.
- [19] K. Huang, "An innovative architecture-level power estimation methodology for godson processor," *Journal of Computer Research and Development*, vol. 44, May. 2007, pp. 782-789.
- [20] D. W. Xu, "Improvement of multi address performance in CDMA system with multiple orthogonal signal modulation," *Journal of Beijing University of Posts and Telecommunications*, vol. 19, Apr. 1996, pp86-89.
- [21] P. Kongetira, "Niagara: A32-way multithreaded Sparc processor," *IEEE Micro*, vol. 25, pp. 21-29, Feb. 2005.
- [22] A. K. Cherri, "One-step optical trinary signed-digit arithmetic using redundant bit representations," *Optics & Laser Technology*, vol. 29, May. 1997, pp. 281-290.
- [23] M. Hossain, "Optical implementation of an efficient modified signed - digit trinary addition," *Optics & Laser Technology*, vol. 30, Apr. 1998, pp. 49-55.
- [24] L. L. Hu, "Influence of the laser's side mode on the performance of 10Gb/s optical quaternary transmission," *Journal of Xidian University*, vol. 32, Aug. 2005, pp. 619-621..
- [25] Y. Jiang, "Development and application of 8-bit PC104 mainboard based MCS51 microcontroller," *Chinese Journal of Scientific Instrument*, vol.28, Jul. 2007, pp. 1229-1233.
- [26] R. C. Jie, "Universal framework of fireware and its design based on PDIUSBD12," *Application Research of Computers*, vol. 22, Sep. 2005, pp. 199-200.
- [27] L. M. Dang, "32-Bit high-precision timer based on the 89C55WD single-chip," *Journal of Surveying and Mapping*, vol. 24, Oct. 2007, pp. 346-348.
- [28] M. Schutti, "VHDL design of embedded processor cores," in *Conf. ASIC. 1998 Proceedings Eleventh Annual IEEE International*, pp. 265-269, Sep.1998 .
- [29] S. S. Teng, "Design of single-chip microcomputer system with lower power for portable intelligent instruments," *Computer Engineering and Applications*, vol. 12, Apr. 2000, pp. 83-87.
- [30] D. Q. Feng, "Study on real-time communication models for Ethernet-based industrial control network," *Chinese Journal of Scientific Instrument*, vol. 26, Sep. 2005, pp. 715-718.
- [31] L. X. Xu, "Analysis and design of application based on 10G Ethernet's technology," *Computer Engineering and Design*, vol. 26, Nov. 2004, pp. 1930-1932.
- [32] N. Yang, "A method of performance measurements of 802.3 LAN," *Journal of Shanghai Teachers University*, vol. 33, Dec. 2004, pp. 46-50.
- [33] Draft A. (2002, Apr.). 10 gigabit ethernet technology overview white paper revision 2. [Online]. Available: <http://www.10gea.org>.
- [34] C. C. Han, "Real-time communication in FieldBus multiaccess networks," in *First IEEE Real-Time Technology and Applications Symposium*, pp. 86-90, April.1995.
- [35] A. V. Scott, "Truly distributed control systems using Fieldbus technology," in *7th IEEE International Conference and Workshop on the Engineering of Computer Based Systems*, pp. 165-170, Sep. 2000
- [36] T. Nolte, "Minimizing CAN response-time analysis jitter by message manipulation," in *Proceedings 8th IEEE Real-Time and Embedded Technology and Applications Symposium (RTAS'02)*, pp 197-206, June 2002.