

Modeling Visual and Auditory Integration of Barn Owl Superior Colliculus with STDP

Juan Huo

School of Electronics and Engineering
The University of Edinburgh
Edinburgh, EH9 3JL, UK
J.Huo@ed.ac.uk

Zhijun Yang

School of Electronics and Engineering
The University of Edinburgh
Edinburgh, EH9 3JL, UK
Zhijun.Yang@ed.ac.uk

Alan Murray

School of Electronics and Engineering
The University of Edinburgh
Edinburgh, EH9 3JL, UK
Alan.Murray@ed.ac.uk

Abstract—The visual and auditory map alignment in the superior colliculus of barn owl is important for its accurate localization in prey behavior. This alignment may be disturbed by the blindness or prism wearing, the juvenile barn owl could adapt its auditory map to this mismatch after several weeks training. It is believed in literature that auditory map with the plasticity shifts in terms of the visual map change. In this paper, a model is built to explain this mechanism. The activity dependent axonogenesis during the auditory map shift is guided by the visual instructive spikes whereas the visual instructive spikes are modulated by an inhibitory network based on spike timing dependent plasticity (STDP). The simulation results are consistent with the biological experiment and would open a way towards artificial networks capable of eliminating the disparity in visual and auditory map integration.

I. INTRODUCTION

We tend to experience the world as single place, because sensory localizations of objects are consistent between each other. This registration of different sensory information are well studied in the superior colliculus (SC) of barn owl. Barn owl is a nocturnal predator that has highly accurate visual and auditory localization. In the barn owl, visual and auditory pathways are believed to be integrated in the deeper layer of SC, which is a paired structure part of the brain's tectal area [1]. The superficial layer of SC accesses visual and auditory information from retina and external inferior nucleus (ICx) [2], [3]. These informations forming visual and auditory maps are projected to the deeper layer of SC. For auditory map, the auditory localization cue of azimuth barn owl used is interaural time difference (ITD). In the topographically organized central inferior colliculus (ICc), neurons are sensitive to both ITD and sound frequency [4]. ICc wraps around ICx. The location cue information in ICc is converged across frequency channels and projected to ICx.

Normally, visual and auditory maps will register with each other. But blindness or lesion will cause the auditory map degraded. To study this experience dependent manner, the juvenile barn owl was worn a prism in [5]. After weeks of training, the firstly disturbed auditory map gradually shifts and rematches the visual map. In terms of [5], axonogenesis and synaptogenesis between ICc and ICx are involved in this adaptation. This adaptation is guided by the instructive signal triggered by the visual map shift, we call it MAC (map adaptation cue). MAC is transferred from SC to ICx when the

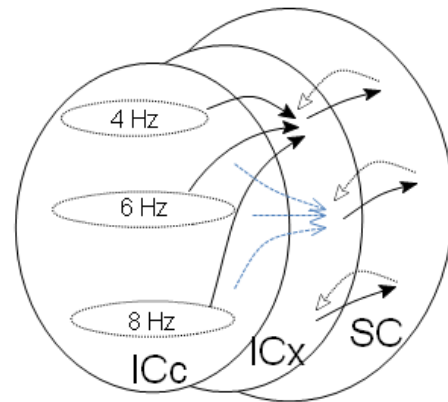

Fig. 1. The anatomy of the visual and auditory pathway. The (smaller area) ICx wraps around the ICc. The arrows show projections between layers. The solid arrows show the auditory stimulus pathway. The hollow arrows send the MAC signals from SC neurons to ICx neurons. The dashed arrows are the new connections resulting from prism experience. This figure is modified from [5], [6].

GABAergic inhibition is blocked [4]. This MAC is calibrated by an inhibitory neural network in SC. The visual activity arising from the SC neuron does not excite ICx neuron if visual and auditory localization cues are the same. But it is strong if visual and auditory maps misaligned with each other [7]. Here we introduce a model to explore this process.

Previous work like [8] has shown the hebbian learning mechanism plays an important role in map alignment, but neurons and network are non physiological, because lots of biological experiment details have not been uncovered at that time. An activity dependent learning, spike-timing-dependent-plasticity (STDP) has the basic feature of hebbian learning [9]. STDP is a learning rule in which the synapse weight is changed by the paired spikes in a time window. Thus the synaptic correlation between visual and auditory input is important in the synaptic modification and map adaptation. The recent work [10] shows STDP could account for circuit-level plasticity in adaptation. However, axonogenesis in terms of STDP has not been explored and MAC is not described quantitatively. In this paper, the relationship between STDP and the activity dependent axon developing will be discussed.

After simulation, the result of the auditory map shift is in line with the biological observation. The map adaptation cue (MAC) is modulated according to the degree of mismatch between visual and auditory space map. The model could possibly be extended to be used in a robotic system for elimination of sensory disparity.

II. METHOD

The model we proposed is a topographic neural network, consisting of 10 pathways and 4 layers (ICc, ICx, SC, retina) as shown in Fig. 3. Every pathway represents an azimuth localization cue around 12° . As shown in Fig. 2, the pathway can be divided into two blocks. Block I is the instructive learning process which has the main plasticity. Block II is the inhibitory neural network which controls the generation of MAC.

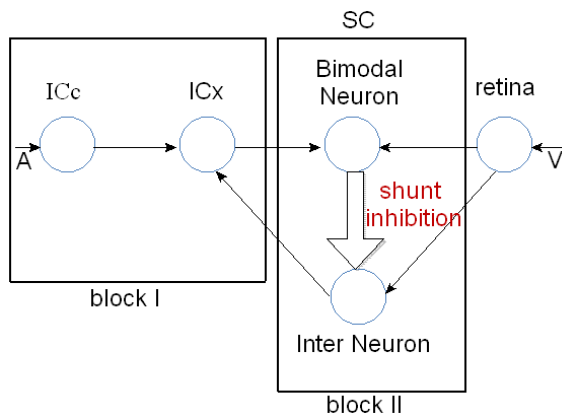

Fig. 2. **The schematic of auditory and visual signal processing pathway.** Neurons are labeled and shown as circles, excitatory connections are depicted as filled thin arrows, the inhibitory connection between SC bimodal neuron and SC inter neuron is an open arrow. Auditory input (A) represents the auditory response. Visual input (V) indicates the visual stimuli. If both A and V represents the object localization in space, this indicates SC bimodal neuron gets two strong correlated input. The synapses connected to the bimodal neuron will be strengthened, the output spike number is highly increased and so is the inhibition towards the inter neuron. In contrast, the disparity between auditory and visual signal source weakens the synapses and reduces the inhibition.

A. The Instructive Learning

The neurons develop new axon connections by extending a precursor called growth cone. Growth cone is sensory to an axon growth factor, Neurotrophin [11]. To describe this system, we index the network by using i to represent the layer and j to label the neuron position in the layer, j is also the pathway number. The postsynaptic spike of j th pathway excites the release of neurotrophin in the ICx layer. For an ICx neuron $N_{2j}(cen)$, the accumulation of neurotrophin is contributed by the activity of any ICx neuron N_{2j} . But this contribution is exponentially decayed by distance from the center neuron $\|N_{2j} - N_{2j}(cen)\|$.

$$D(N_{2j} - N_{2j}(cen)) = e^{-\lambda|N_{2j} - N_{2j}(cen)|}$$

$$c(N_{2j}(cen)) = \sum_{N_{2j}} P(N_{2j}) D(N_{2j} - N_{2j}(cen)) \quad (1)$$

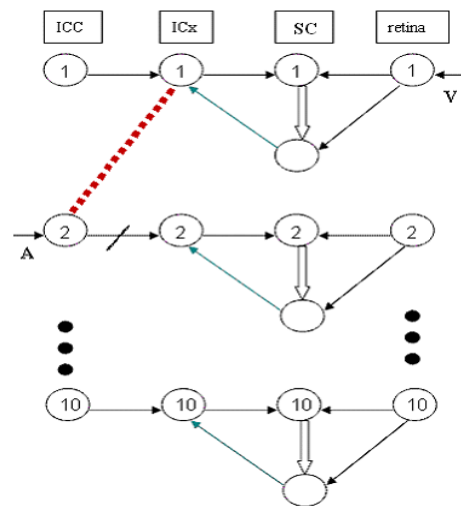

Fig. 3. **Schematic of the network after visual and auditory re-alignment by wearing the prism.** The visual stimuli arrives at retina-1, ICx-1 receives the most strong MAC. But the auditory stimuli arrives at ICc-2, the axon growth cone from ICc-2 is attracted by the neurotrophin released by ICx-1 and the new connection is built, which is depicted as dashed line between ICc-2 and ICx-1. Although the original connection between ICc-2 and ICx-2 is kept, the information path is blocked due to axonal conductance depression.

In this model, the axon sprouting source is ICc layer. The growth cone is activated by the presynaptic activity of ICc neuron N_{1j} . The presynaptic activity of N_{1j} is summed together. The growth cone which is possible to be extended is the most active one. The developing direction of the most active growth cone depends on the identification of the target node $N_{2j}(tag)$ in the ICx layer with the most neurotrophin. When the neurotrophin is accumulated to threshold, the new axon connection is established and the old axon connection is inhibited because of axon bifurcation. Meanwhile, the neurotrophin is reset to initial state.

$$N_{2j}(tag) = \operatorname{argmax}_{N_{2j}(tag) \in Y(N_{2j})} c_{2j} \quad (2)$$

B. Inhibitory Neural Network

The inhibitory neural network includes bimodal neuron and inter neuron. The bimodal neuron accesses both visual signal and auditory signal. Different from the bimodal neuron, inter neuron is a unimodal unit. The inter neuron conveys the visual signal from retina to ICx. The hypothesis of the inter neuron is based on the biological observations in [4].

This model is constructed by leaky integrate and fire (LIF) neuron. As shown in Fig.2, two input synapses of bimodal neuron are excitatory synapses with excitatory synaptic conductance g_e and excitatory reversal potential V_{exc} , the connection between SC bimodal neuron and inter neuron is inhibitory synapse with inhibitory synaptic conductance g_i and inhibitory reversal potential V_{inh} . Parameters in equation 3: $V_{rest} = -70mV$, $V_{exc} = 0mV$, $V_{inh} = -70mV$, $\tau_m = 5ms$. Shunt inhibition is introduced in this model. With the strong inhibitory synapse, the neural membrane potential of inter neuron is more difficult to arrive at the firing threshold [12].

$$C \frac{dV(t)}{dt} = -g_l(V(t) - V_{rest}) - g_e(V(t) - V_{exc}) - g_i(V(t) - V_{inh}) \quad (3)$$

The correlated spike trains are more likely to increase the synaptic weight with STDP [9], [13]. When the auditory stimuli and visual instructive stimuli are generated with the same space localization cue, their correlation is stronger and more output spikes from SC bimodal neuron are generated. This increases the inhibition of the inter neuron and less MAC are conducted to ICx neurons. Conversely, when visual and auditory maps are mismatched with each other, more visual instructive stimuli will be induced to ICx layer.

C. The Input Spike Train Generating

In this model, the visual and auditory input spike trains are generated by inhomogeneous poisson process [14]. This is because physiological studies have shown the neural spikes are stochastic events. The spike trains are triggered short bursts of equal-amplitude spikes [15], [16]. As the stimuli repeated for simulation, the spike clusters are triggered periodically. To modulate the correlation between visual and auditory input and make the spikes arrive in cluster, the firing rate of the inhomogeneous poisson spike train varies as a quarter wave rectified cosine function and the maximum firing rate r_{max} is proportional to the corresponding neuron response strength.

$$F(t) = \begin{cases} 1, & nT \leq t \leq nT + \frac{T}{4} \\ 0, & \text{elsewhere} \end{cases} \quad (4)$$

$$R_A = r_{max_A} * \cos\left(\frac{2\pi}{T} * t\right) F(t) \quad (5)$$

$$R_V = r_{max_V} * \cos\left(\frac{2\pi}{T} * (t - \theta * T)\right) F(t) \quad (6)$$

$$\theta = -0.5 \sim 0.5 \quad (7)$$

Here, T is the varying period. θ is the modulator of the correlation between visual and auditory input, it depends on the disparity between visual and auditory input. The phase shift between R_V and R_A decreases the correlation. The correlation is the lowest if $\theta = 0.5$, namely the phase shift is just half the period.

III. RESULT

The proposed model is simulated for a virtual environment. To test the adaptive axonal remodeling between ICx and ICc, we assume the GABAergic inhibition of visual instructive signal has been blocked [7]. The performance details of this system are as follows.

A. Synaptic Plasticity in the Inhibitory Learning

To test the inhibitory network, we begin by examining the single pathway with strong visual stimuli and correlated strong auditory stimuli. It means the visual localization cue is in register with auditory localization cue. The spike train firing rate for the inhomogeneous poisson process is set to be $r_{max_V} = r_{max_A} = 150$. The phase shift is $\theta = 0$ to make the correlation high. As indicated in Fig. 5(a)(c)(e), both the visual

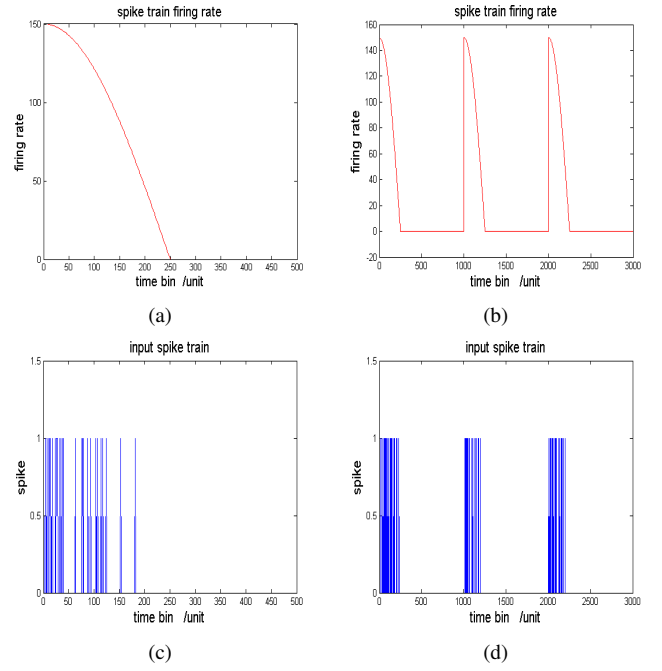

Fig. 4. **The spike trains generated by the poisson process.** (a)(c) The spikes cluster is generated by a quarter wave cosine function. (b)(d) The spike train is generated by repeated spikes clusters.

and auditory excitatory synapses that are connected to the bimodal neuron are strengthened. Therefore, the postsynaptic spike firing rate of the bimodal neuron is high. Via the inhibitory connection, the inter neuron is strongly inhibited. The spike output firing rate is represented as the average spikes number in certain time interval. The comparison of the spike output number between bimodal neuron and inter neuron is shown in Fig. 5(e) when synaptic state is nearly stable. The selected time bin begins from the 6th unit. There's nearly no inter neuron output. This result is similar as the observation in biological experiment.

We then examine the single pathway with strong visual stimuli but weak auditory stimuli. The correlation between them is the least. It emulates the case that the retina neuron in this pathway is in the visual receptive field center, but the ICc neuron of this pathway dose not correspond to the object localization. Parameters: $r_{max_V} = 150, r_{max_A} = 50, \theta = 0.5$. Fig. 5(b)(d)(f) show the disparity between visual and auditory map which decreases the strength of the auditory synapse connecting ICx with the bimodal neuron. The visual excitatory synapse is strengthened because the visual input spike train has higher firing rate and thus is more likely to win in synapse competition in terms of STDP. But the firing rate of the postsynaptic spikes is decreased in the bimodal neuron. Since there are less spikes to get through the inhibitory connection between the bimodal neuron and the inter neuron, the inhibitory current towards the inter neuron is reduced. This leads to the higher firing rate of the inter neuron, since it is easier for inter neuron to get its membrane threshold. Because

the excitatory current towards the inter neuron mainly comes from the visual excitatory synapse, the inter neuron output will basically follow the change of the visual input of this pathway.

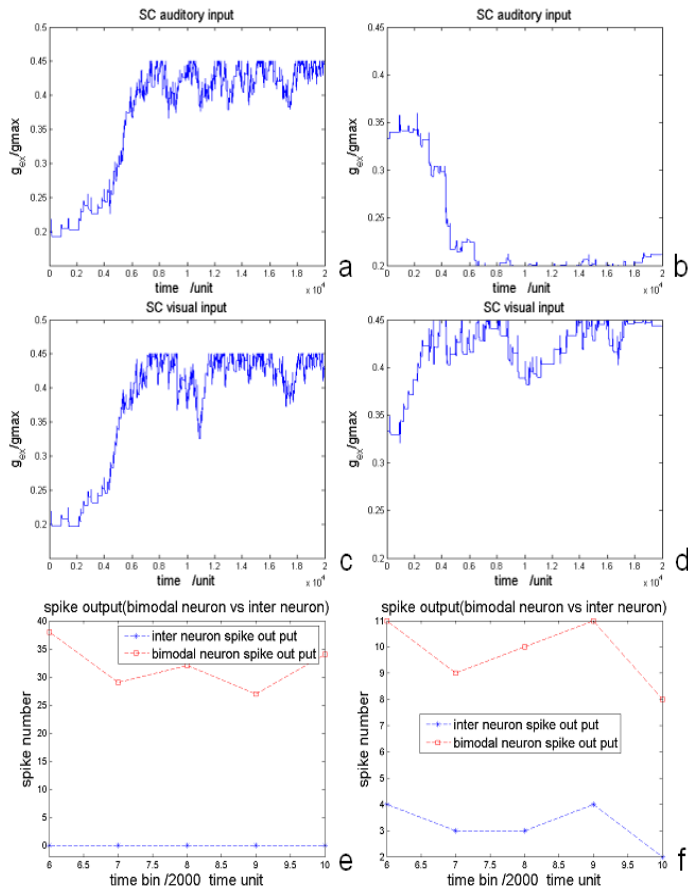

Fig. 5. **The synaptic weight change and the statistics of the SC postsynaptic spikes number.** $\theta = 0, rmax_A = rmax_V = 150$ in (a)(c)(e), the visual and auditory input spike trains are highly correlated. (a) The visual synaptic weight. (c) The auditory synaptic weight. (e) The high correlation between A-V input increases the bimodal neuron firing rate but strongly inhibit the inter neuron. $rmax_V = 150, rmax_A = 50, \theta = 0.5$ in (b)(d)(f), the correlation between visual and auditory input spike trains are low. In contrast to (a)(c)(e), the auditory synaptic weight in (b) is decreased. (f) The bimodal neuron firing rate is lower than it is in (e), the average inter neuron firing rate is obviously up to a new level.

To find the influence of the disparity on visual and auditory map, θ vaules are tested in 20 simulations. The averaged spikes output numbers of an inter neuron for different θ values are shown in Fig. 6. In these simulations $rmax_V = 150, rmax_A = 50, \theta$ varies from -0.5 to 0.5. The inter neuron is strongly inhibited when visual and auditory stimuli are correlated at the point $\theta = 0$, namely the visual and auditory stimuli originate from the same localization. The inter neuron becomes more active as the correlation decreased. This result is consistent with Fig. 6(a), which described that the visual response appearing in the ICx depends on its relation with the best ITD of the site.

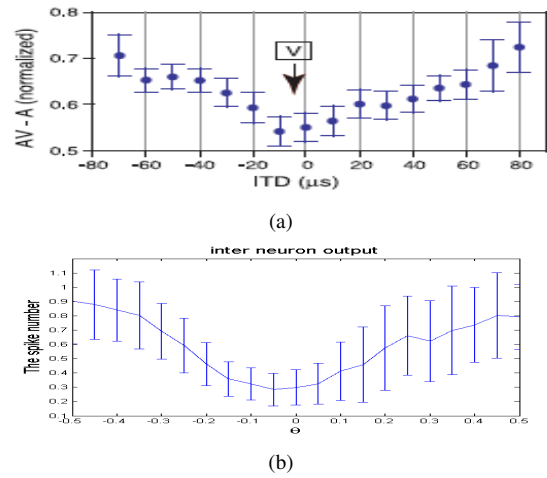

Fig. 6. **The visual response of the ICx neuron.** (a) The average difference between the response to the auditory-visual stimulus and the response to the auditory stimulus alone(AV-V) versus the ITD of the sound relative to the best ITD. This figure comes from [4] with the permission of the author. (b) The average spikes number in each time bin (1000 time unit) of the inter neuron output after 20 simulations. The error bars indicate the standard deviation between simulations.

B. Map Shift in ICx

The input spike trains for the complete visual and auditory maps are generated by inhomogeneous poisson process. The spike trains which represent the target localization cue have the maximum firing rate and share the same θ .

The visual instructive spikes from the inhibitory network exhibiting in the ICx neuron releases the neurotrophin. When the accumulation of the neurotrophin as shown in Fig. III-B reaches the threshold, the neurotrophin is reset to the original state, meanwhile the new axon connection is established but the old connection is blocked.

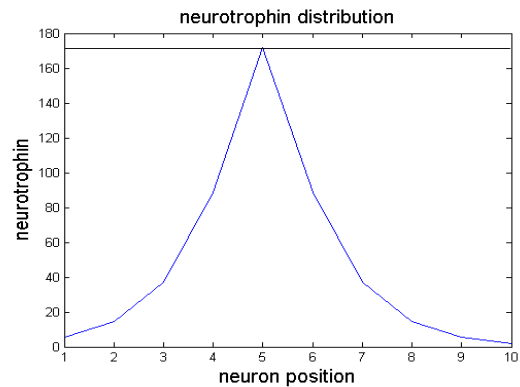

Fig. 7. **Plot of neurotrophin accumulation in ICx layer.**

The original ICx map arrangement is normal as shown in table I. The virtual prism angle we set is 24° . Thus the most correlated viusal and auditory spike trains are not in the same pathway. After enough amount of simulations, all the azimuth angles have been experienced, every ICc neuron is connected to the forward two ICx neuron as shown in table II.

TABLE I

THE ARRANGEMENT OF AXON CONNECTION BEFORE PRISM LEARNING

| | axon connection | | | | | | | | | |
|--------------|-----------------|---|---|---|---|---|---|---|---|----|
| source nodes | 1 | 2 | 3 | 4 | 5 | 6 | 7 | 8 | 9 | 10 |
| target nodes | 1 | 2 | 3 | 4 | 5 | 6 | 7 | 8 | 9 | 10 |

TABLE II

THE ARRANGEMENT OF AXON CONNECTION AFTER PRISM LEARNING

| | axon connection | | | | | | | | | |
|--------------|-----------------|---|---|---|---|---|---|----|---|----|
| source nodes | 1 | 2 | 3 | 4 | 5 | 6 | 7 | 8 | 9 | 10 |
| target nodes | 3 | 4 | 5 | 6 | 7 | 8 | 9 | 10 | - | - |

IV. CONCLUSION

Here we described a model with the essential characters of SC sensory integration with the newest biological discoveries [6]. This model provides a new plasticity structure to explain the visual and auditory map alignment in the SC of barn owl. The axonogenesis modeling between ICx and ICc is the first time to be introduced. The developing axon is guided by the visual instructive information which is controlled by the inhibitory network in SC. It is the first time the function of the inhibitory network is well explored. The excitatory synapses in the inhibitory network are adjusted by STDP which is sensitive to the correlations between input spike trains. We use inhomogeneous poisson process to translate the sensory stimuli to spike trains. The correlation is calibrated by the modulator θ .

Plasticity of this mechanism eliminates the visual and auditory disparity for the target localization. For future work, the plasticity of the auditory map will be extended by axonogenesis and synaptogenesis integration. New synapses formation and elimination at the end of the axonal connection will be discussed. This model could also be developed to be more artificial which can be embedded in robotic system.

V. ACKNOWLEDGEMENT

We would like to thank EPSRC's financial support, Sim Bamford for his suggestion which triggered our initial interest in saccadic system. We would also thank Leslie Smith for his support in the STDP Matlab coding.

REFERENCES

- [1] M. F.Bear, B. W.Connors, and M. A.Paradiso, *Neuroscience:Exploring the Brain*. USA: Lippincott Williams & Wilkins, 2001, ch. 9, pp. 292–295.
- [2] B. MS and K. EI., “Sensitive periods for visual calibration of the auditory space map in the barn owl optic tectum,” *J.Neurosci*, vol. 18, pp. 3929–3942, May.
- [3] J. Schnupp, “The development of the auditory space map in the superior colliculus: Explorations around a hebbian hypothesis,” Ph.D. dissertation, University of Oxford, 1996.
- [4] Y. Gutfreund, W. Zheng, and E. I. Knudsen, “Gated visual input to the central auditory system,” *Science*, vol. 297, pp. 1556–1559, 2002.
- [5] J. I.Gold and K. EI., “Adaptive adjustment of connectivity in the inferior colliculus revealed by focal pharmacological inactivation,” *J Neurophysiol.*, vol. 85(4), pp. 1575–84, 2001.
- [6] K. EI., “Instructed learning in the auditory localization pathway of the barn owl,” *Nature*, vol. 417, no. 6886, pp. 322–328, May 2002.
- [7] Y. Gutfreund and E. I. Knudsen, “Adaptation in the auditory space map of the barn owl,” *J Neurophysiol.*, vol. 96, pp. 813–825, 2006.
- [8] R. M, T. G, and E. GM., “Registration of neural maps through value-dependent learning: modeling the alignment of auditory and visual maps in the barn owl’s optic tectum,” *J Neurosci.*, 1997.
- [9] S. Song, K. D. Miller, and L.F.Abbott, “Competitive hebbian learning through spike-timing-dependent synaptic plasticity,” *Nature Neurosci*, vol. 3, pp. 919–926, 2000.
- [10] S. P.Mysore and S. R. Quartz, “Modeling structural plasticity in the barn owl auditory localization system with a spike-time dependent hebbian learning rule,” in *Neural Networks, 2005. IJCNN '05*, vol. 5. 2005 IEEE International Joint Conference, 31 July–4 Aug. 2005, pp. 2766–2771.
- [11] B. Taba and K. Boahen, “Silicon growth cones map silicon retina,” *Advances in Neural Information Processing System*, vol. 18, 2006.
- [12] L.F.Abbott and P. Dayan, *Theoretical Neuroscience*. Cambridge: MIT Press, August 2001, ch. 6.
- [13] J. Huo and A. Murray, “The role of membrane threshold and rate in stdp silicon neuron circuit simulation,” in *Artificial Neural Networks: Formal Models and Their Applications - ICANN, 2005*.
- [14] K.-I. Amemori and S. Ishii, “Gaussian process approach to spiking neurons for inhomogeneous poisson inputs,” *Neural Computation*, vol. 13, pp. 2763–2797, 2001.
- [15] F.-S. LO and R. R. MIZE, “Retinal input induces three firing patterns in neurons of the superficial superior colliculus of neonatal rats,” *J Neurophysiol*, vol. 81, pp. 954–958, 1999.
- [16] R. Schaeffe, T. Gollisch, and A. Herz, “Spike-train variability of auditory neurons in vivo: dynamic responses follow predictions from constant stimuli,” *J Neurophysiol*, vol. 93, no. 6, pp. 3270–81, 2005.