

Community Intrusion Detection and Pre-warning System Based on Wireless Mesh Network

Meijuan Gao^{1,2}, Jingwen Tian^{1,2}

¹⁾Department of Automatic Control
¹⁾Beijing Union University
Beijing, China
ttgg500@163.com

Kai Li², Hao Wu²

²⁾School of Information Science
²⁾Beijing University of Chemical Technology
Beijing, China
tjjjww999@163.com

Abstract—A community intrusion detection and pre-warning system based on wireless mesh network is presented in this paper. This system is composed of ARM (Advanced RISC Machines) data acquisition nodes, wireless mesh network and control centre. The flame, smog and infrared signal of human can be detected by ARM nodes, and video and audio signal is collected and transmitted to control centre by wireless mesh network when any of those situation happened. The control centre stores information to special area and gives alarm signal to monitors. The ARM data acquisition nodes use embedded system use its centre control unit and transmit signal by wireless transmission module which can connected to ARM9 and send video and audio signal. The system can establish network automatically by using the advantage of multi-hop communication of mesh network. Redundancy node can be placed on important area to make sure reliability and resist destroy.

Keywords—wireless mesh network, intrusion detection, pre-warning, community

I. INTRODUCTION

The concept to residence of people have transformed to humanness form just only habitation originally by the development of economy and rising of life level. Safety, comfort and convenience have become the main point of the development of the residence, and safety is chief destination among them. The implement of safety depend on security system mostly besides man-made factors.

Community intrusion detection and pre-warning system of wireless sensor network based on ARM is a kind of important security defense system. It can be used in residential sub-districts, office etc. Present community intrusion detection system of sensor network puts camera in the surveillance range. Camera directly sends information to the control centre. Workers who work at the room of control centre give judgment through the received information. So this kind of system has a less intelligence, if workers did not find the intruded action, the safety of community will difficult to ensure. Also, it is difficult to find the intruded action from a lot of stored images, if the intruded actions have been happened.

Recently, security defense system contains the following three parts: Omnibearing defense system, TV monitoring system and electrical inspection system. Omnibearing defense system which place some infrared ray detector on public area

and use camera connected to alarm system of residence by wire. TV monitor system is design for some important places and go on monitor for 24 hours for example park, entrance of community, the spacing and wall of community and so on [1]. Electrical inspection system is used to supervise workman make sure that he have check everywhere on route. The workman complete the task and connect the polling detector to the computer of the control centre by special communicate wire, the computer manages the data. These systems have some influence of development of building security and improve the defense ability in some degree [2].

But because of the concentrated manage and communicate by wire, some problems are existed as follow: Some danger hidden in communication by wire, intruder can cut the wire easily as much as destroy the entire system. TV monitor which detect the area continuously 24 hours wastes lots of electricity resource and bring a problem about great capacity data (lots of which is useless) storage. These systems all need people to intervene in, so all need people to monitor at last and have a low intelligence and waste lots of human resource and the community safety is difficult to ensure if workers do not find the problem in time.

To solve these problems, the paper presents a community intrusion detection and pre-warning system based on wireless mesh network. First, the system builds network automatically based on mesh network and in advantage of automatic route, so avoid the entire system problem aroused by a fault in region. Second, the node designed based on ARM collect the video and audio signal when some abnormality happen, so the problem about large capacity data involved in collect, transmit and store do not exist. In addition, we use image processing arithmetic to analyze information which collected from sensors, then sends analyzed result to workers and automatic stores images in a special memory area if there are intruded actions. Finally, some redundancy nodes are placed in important area to make sure that this system have a high reliability and ability to resist destroy.

II. SYSTEM NETWORK DESIGN AND WORKING PROCESS

This system is composed of ARM data acquisition nodes, wireless mesh network and control centre. System nodes use ARM platform that expanded by sensors. There are flame sensor, smog sensor, infrared sensor, microphone and video

camera. Wireless local area network uses wireless mesh network. Control centre uses workstation computer. Distribute node collect signal and build network by multi-hop. So, the whole system has advantages of low-power, convenient for expand software and hardware, network communication and conveniently fixed in security defense places.

When the intrusion detection and pre-warning system works, the flame sensor and smog sensor of ARM node starts to detect whether the fire exists. If the fire is found, ARM node sent up fire signals and controlled the sound and light alarm to remind worker put out the fire. The human infrared sensors and complexion detection algorithm are used to detect whether people have come in, and the reliability of the system will be improved and the misinformation caused by the animal can be avoided. When there is abnormal phenomenon, the system starts the camera and microphone, the ARM nodes collect image and sound signal, and these signals were sent to the control centre. Then in the control centre, the image and abnormal information were stored in special memory. In the evening, when photoresistor sensor signal and infrared sensor signal are simultaneously received, system opens the highlight diode lights around camera, so the energy is saved, and at the same time ensured that camera still captures effective images in the dark.

When information transmits by network, signal is sent to the network control centre with wireless mesh network transmission protocol. When information is obtained, control centre will adopt different processing mode according to the different alarm information. If there is invasion signal, the invasion process will be stored in a specific memory. No invasion signal, then display images and stored them in memory. Even if it was not timely noted the invasion, workers can also look for specific storage area, find out the invasion. If receive fire alarm signal, the conflagration area is showed in display. System general structure is shown in Fig. 1.

The whole network is constructed with hybrid network of wireless mesh network. Every nodes of wireless mesh network is a router as well as an access point. Node can send and receive information and directly communicate with one or more neighboring nodes.

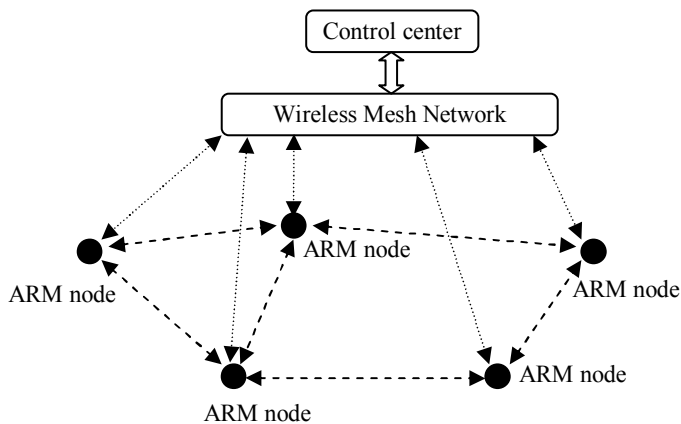

Figure 1. The system network structure

The distant range other nodes can be communicated by mobile communication network lay. And, nodes can also communicate with control centre with mobile communication network lay. So, in the multi-hop method, we can avoid lose data and ensure data is safely transmitted to control centre. As the self-organization and self-adaptive capacity of the mesh network, when there are lose nodes or add nodes, route table can be automatic modified, which improved system robust [3].

For mobile communication network, the Firetide HotPort is adopted in this system. This kind of network uses the new multi-hop wireless network technology which is complete different from the traditional wireless network. Its Ethernet direct technology transforming the multi-hop into single hop, which gains 20M multi-hop wireless networks, avoids the reduction of bandwidth which is caused of the multi-hop data transmission in traditional wireless mesh network.

ARM network sensor nodes choose to use the 802.11g protocol which works in the 2.4 GHz ISM band to access the mesh network [4]-[5]. The physical layer of 802.11g adopts the OFDM (orthogonal frequency division multiplexing) modulation method and modulates Preamble, Header and Payload respectively. The transmission rate can go up to 54 Mbit/s. It can transmit the image and acoustic data.

III. HARDWARE DESIGN OF ARM DATA ACQUISITION NODE

ARM nodes are fixed in the importance security defense range. The hardware of ARM node is composed of process unit and extended sensors. The structure diagram of ARM node is shown in Fig. 2.

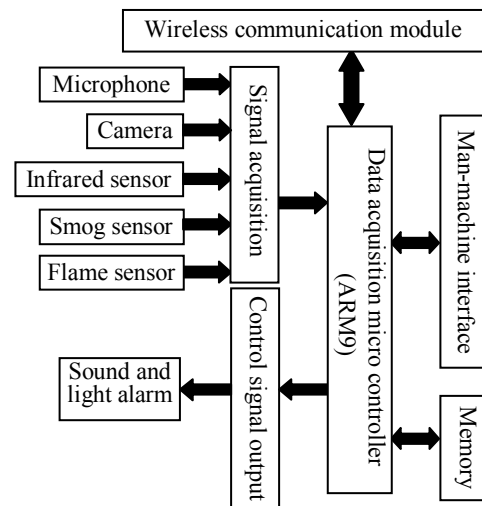

Figure 2. Structure diagram of ARM node

A. Processor Cell

ARM technology is the mainstream of the embedded system. At present, the ARM chips in the market can even reach a speed of several trillion, and the systems use these chips as their main controller can build up a system of data collection, data process and communication with high speed

and high precise. The data acquisition node adopted the processor S3C2410 of the Samsung Company, combined with the μC linux operate system to realize the designed function. S3C2410 is a type of low price, low power loss, and high behavior microprocessor of 16/32 bits, which performs quite well in the application field of embedded system [6].

CPU uses the processor S3C2410 which is ARM920T kernel processor includes USB HOST and USB DEVICE interface. The system presented in this paper uses USB HOST interface. Flash chooses Samsung's K9F1208 chip which is 64M. SDRAM, type is HY57V561620AT-H.

B. Wireless Transmission Module

We use wireless network card to transmit data, which type is TP-LINK TL-WN321G, 802.11g bus standard, USB interface, transmission speed is 54Mbps, full duplex, starting on wireless mesh network, wakeup on wireless mesh network. It can transmit video and audio data.

C. Microphone

The audio frequency decode chip UDA1341 and microphone is chosen by the system for the audio module. UDA1341 is connected to S3C2410 via I²S bus, while I²S bus provides the transmission channel for data stream, GPG8, 9, 10 is chosen to control the chip. Circuit map is shown in Fig. 3.

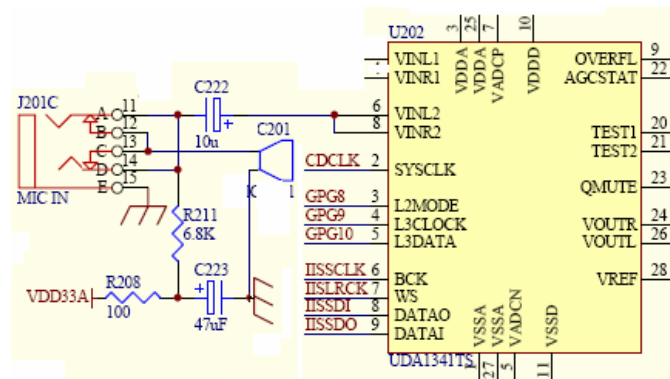

Figure 3. Microphone connecting circuit

D. Sensor Cell

Sensor unit includes camera, microphone, human infrared sensors, flame sensors, smog sensors, photoresistor sensors, sound and light alarms. Hardware is shown in Fig. 4.

Camera uses USB HOST interface communicates with ARM [7]. Camera control chip type is TP6800 which offers four transmission ports. Port 0 is default pipeline that communicates with ARM using control transmission command and sends device request commands. Image sensor uses Hynix's COMS Image Sensor HV7131R which connect with TP6800 using IIC interface.

Human infrared sensors use BISS0001 infrared detection components, the component working voltage is 5 V, working temperature is -20°C-70°C, maximum detection distance is 7m.

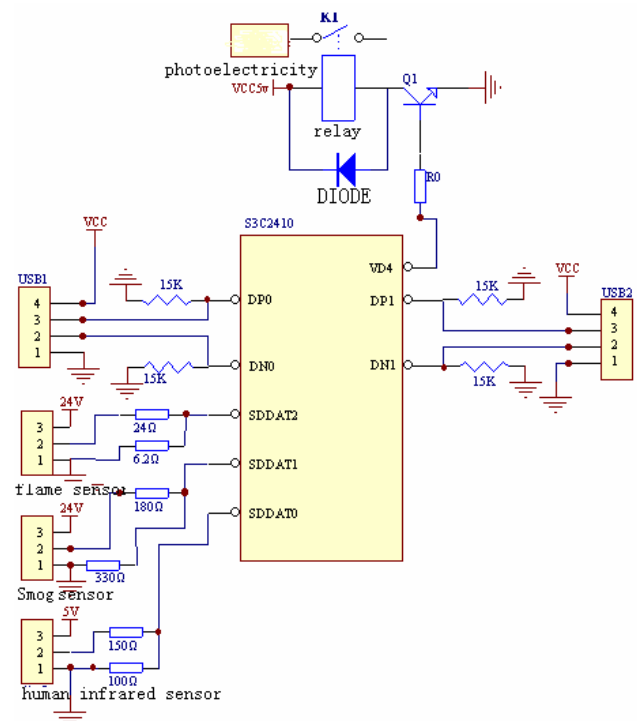

Figure 4. Sensors connecting circuit

When someone is detected, the infrared detection component outputs high-level 4.25V, otherwise, it outputs low level 0V.

Flame sensor: Flames is detected through XZ2-BZY-60 flame detector. It includes flame sensor and controller two parts. It has simple structure and easy installation. It can reliably detect, monitor flame. Working voltage is DC24V, when need alarm, internal relay is on state, output voltage is 24V.

Smog sensor: Producing smog is a physical phenomenon when the fire occurred. It is an important message. This sensor uses JTY-GD-T12 type photoelectric smog detectors. Its work voltage is from DC8V to 28V wide-voltage, its working environment is from -10°C to 50°C. The detector built-in intelligent processor and automatic drift compensation algorithm. When reached built-in smog alarm threshold, the smog detection alarm and output 5V voltage signal.

Sound and light alarms: The system uses AE9102, this product accord with GA385-2002 standards, working voltage is 18 VDC-28VDC, when it works below the 24 VDC, the current is less than 60mA, intensity flash is 110cd, flash frequency is 26-30 times/minute, the working environment is from -10°C to -60°C. Sound and light alarm through relay power supply. When the relay closed, sound and light alarm started work.

Highlight light-emitting diodes: When the light is too dark and some abnormality occur, abnormal signal and photoresistor sensor signal control highlight light-emitting diode together and start the camera and microphone, so the system can collect the data in the night. The circuit diagram is shown in Fig. 5.

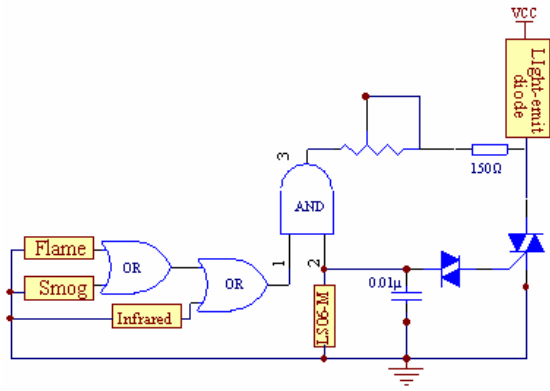

Figure 5. Circuit diagram of high-light-emitting diode

IV. SOFTWARE DESIGN

The $\mu\text{C-OS II}$ embedded operation system is used in program design [8]-[10]. Programming environment uses ADS. The system general flow chart is shown in Fig. 6.

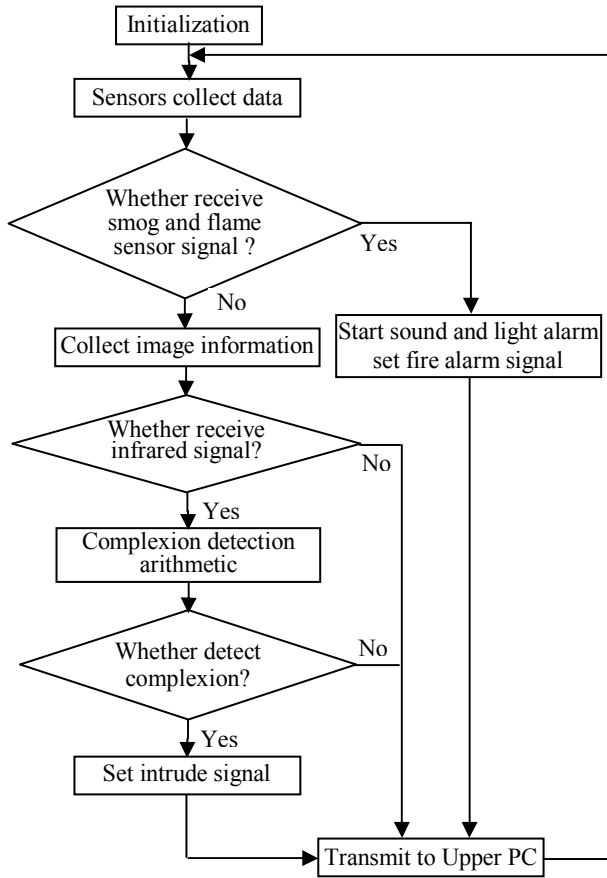

Figure 6. System general flow chart

A. Initialization

Initialization part completes hardware configuration of ARM platform, which includes A/D module, keyboard, LCD, USB camera interface, internet interface and $\mu\text{C-OS II}$.

B. Sensor Data Acquisition

Smog sensor and flame sensor collect signal. When produce the smog and flame signal, start sound and light alarm and set fire alarm signal, collect and transmit the video and audio data to control centre. At the same time, when human infrared sensor module put out signal, the camera and microphone are started and collect the image and sound signal on the scene and then begin complexion detection algorithm, and then sends the result and image of camera to control through wireless mesh network. If there is no infrared signal and didn't found complexion, collected information will be directly transmitted to control centre through wireless network.

C. Data Processing

Pretreatment part: decompressing the JPEG image in memory, translate it into 24 bit true color format [11]. Please pay attention to following 4 points in storing the picture: first, the true color image doesn't have color palette. Second, true color image uses three bytes denotation one pixel, the three bytes sequence is B, G, R. Third, The byte number of one scanning line of the image must be the multiple of four. The last, When storing the image, the store sequence is from left to right and from down to up.

Complexion checking arithmetic: complexion has invariability, complexion is impacted with the change of the image is very little. There is no changing however the image is magnified or reduced. So, we can adopt the complexion checks human face and eventually extracts it from the image [12]-[15]. Firstly, the RGB image needs to translate into $YCrCb$ color mode space. Y denotes the brightness information of the image, Cr denotes the red heft of the lamp-house, Cb denotes the blue information of the lamp-house. Translate RGB color module space to $YCrCb$ using formula (1).

$$\begin{bmatrix} Y \\ Cb \\ Cr \end{bmatrix} = \begin{bmatrix} 0.299 & 0.587 & 0.114 \\ -0.1687 & -0.3313 & 0.5 \\ 0.5 & -0.4187 & -0.0813 \end{bmatrix} \times \begin{bmatrix} R \\ G \\ B \end{bmatrix} \quad (1)$$

The brightness has little impacts in $YCrCb$ space and this space is an independent two dimension distributing space. So, it can well restrict the skin-color's distributing area. Experiments have been proved that although different people's skin-color may be wide difference, but the difference in skin's chroma is less than the difference in skin's brightness. So the conclusion is skin-color of different people are similar in the chroma, just a lot of difference in the brightness. Different skin-color have the similar 2D Gaussian model $G(m, V^2)$.

$$m = (\overline{Cr}, \overline{Cb}) \quad (2)$$

$$V = \begin{bmatrix} \sigma_{Cr,Cr} & \sigma_{Cr,Cb} \\ \sigma_{Cb,Cr} & \sigma_{Cb,Cb} \end{bmatrix} \quad (3)$$

here, $\overline{Cr} = \frac{1}{N} \sum_{i=1}^N Cr_i$, $\overline{Cb} = \frac{1}{N} \sum_{i=1}^N Cb_i$.

Through building skin module, translates color image into gray-scale image, gray-value corresponds the possibility of skin area. Choosing a suitable threshold translates gray-scale image into binary image. We use “0” denotes skin area and “1” denotes non-skin area. According transcendental skin character which Cr equal to 158.443 and Cb equal to 122.458 extracts the skin area and sets them with white, the other area sets with black. If the skin area is detected, ARM node requires control centre stores image in the special memory and gives an alarm signal to workers.

V. CONCLUSION

The community intrusion detection and pre-warning system of wireless sensor network based on embedded system proposed in this paper can monitor multi danger signal simultaneously such as intrusion of human, flame, smog, water leak, poisonous gas etc at every data acquisition node. This system can accomplish the community security defense monitoring fleetly by using the quick speed processing capacity of ARM and combine with wireless mesh network communication. Redundancy node can be placed on important area to make sure reliability and resist destroy. This system resolves the defect of worker to supervise, improves the intelligence and alleviates worker’s working stress to a great extend. Intruded accidents can be found out immediately even though worker didn’t find at time. Community safety can get a better protection. In general, this intrusion detection system has advantages of lower cost, lower power, convenient fixing etc, and it also has a better application foreground.

ACKNOWLEDGMENT

This work was supported in part by the National High Technology Research and Development Program of China (863

Program) under Grant #2005AA420070-1 and Beijing Education Special Project under Grant PXM2008_014209_063030.

REFERENCES

- [1] Shizhu Yin, “Intellectual security system of residence based on video monitor,” Knowledge and technology of computer, no. 3, 2006.
- [2] Yunxia Liu, “Perspective of security system of intellectual residence,” Scientific information and economy, no. 7, 2007.
- [3] Wei Xie, Mingbo Xiao, Yan Yao, WMN: A New Type of Wideband Wireless Network, Telecommunications Science, Vol.22, No.6, pp.48-52, 2006.
- [4] Osama Aboul-Magd, et al, Joint SEE-mesh/Wi-mesh proposal to 802.11 TGs, doc-IEEE 802.11-06/0328r0, 2006-02-27.
- [5] Santosh Abraham, Jonathan Agre, Hidenori Aoki, et al. 802.11 TGs simple efficient extensible mesh (SEE2Mesh) proposal, 2006.
- [6] S3C2410X 32-BIT RISC MICRO PROCESSOR USER'S MANUAL. <http://www.samsung.com>.
- [7] Lei Guo, Qizheng Liao, Shi-min Zheng, Kun Cai, Wei Li, Design of USB WLAN Device Driver Based on ARM9, Application of the Computer System, No.1, pp.92-94, 2007.
- [8] Wang Tianmiao, Embedded system design and experiment development, Tsinghua University Press, Beijing, China, 2002.
- [9] Embedded system experiment instructor. Beijing Universal Pioneering Technology Co., LTD (UP-TECH). www.up-tech.com.
- [10] Jing Xu. Embedded System Design & Development Example Analyzing in ARM, Bei Hang University Press, Beijing, China, 2005.
- [11] Qingfang Zheng, Wen Gao, Adaptive Skin Detection in JPEG Compressed Images, Journal of Computer Research and Development, pp.1194-1200, 2006.
- [12] J.Yang,T.Tan, W. Hu, Skin color detection using multiplecuesm, In: Int'l Conf. Pattern Recognition, Los Alamitos, IEEE Computer Society Press, 2004.632-635.
- [13] Yang M H, Kriegman D, Ahuja N, Detecting faces in images: A survey, IEEE Trans Pattern Analysis and Machine Intelligence, Vol.24, No.1, pp.34-58, 2002.
- [14] Jin Z, Yang J Y, Hu Z S, et al, Face recognition based on the uncorrelated discriminate transformation, Pattern Recognition, Vol. 34, No.7, pp.1405-1416, 2001.
- [15] Kin K I, Jung K, Kim H J, Face recognition using kernel principal component analysis, IEEE Signal Processing Letters, Vol.9, No.2, pp.40-42, 2002.