

Mobile Robot with Preliminary-announcement and Indication Function of Forthcoming Operation using Flat-panel Display

Takafumi Matsumaru

Abstract—This research aims to propose the method and equipment to preliminary-announce and indicate the surrounding people both the speed of motion and the direction of motion of the mobile robot that moves on a two-dimensional plane. This paper discusses the mobile robot PMR-6, in which the liquid crystal display (LCD) is set up on the mobile unit, and the state of operation at 1.5 s before the actual motion is indicated. The basis of the content to display is 'arrow' considering the intelligibility for people even at first sight. The speed of motion is expressed as the size (length and width) of the arrow and its color based on traffic signal. The direction of motion is described with the curved condition of the arrow. The characters of STOP are displayed in red in case of stop. The robot was exhibited to the 2005 International Robot Exhibition held in Tokyo. About 200 visitors answered to the questionnaires. The average of five-stage evaluation is 3.56 and 3.97 points on the speed and on the direction respectively, so the method and expression were evaluated comparatively intelligible. As for the gender, the females appreciated about the speed of motion than the males on the whole. Concerning the age, some of the younger age and the upper age admired highly about the direction of motion than the middle age.

I. INTRODUCTION

This research aims to propose the method and equipment to preliminary-announce and indicate the surrounding people both the speed of motion and the direction of motion of the mobile robot that moves on a two-dimensional plane. This paper discusses the design and the basic characteristic of the mobile robot PMR-6 (Fig. 1) with a flat-panel display.

Recently with the coming of the decreasing-birthrate society and the aged society, the application and the practical use of the robotics and mechatronics technology are expected not only to help and support elderly or physically handicapped people but also to assist ordinary people in daily life. Therefore the number of the human-coexisting type robot that works in the same living space or the same working space as people is increasing. Such human-coexisting type robot should avoid contact or collision with people. Then various researches on safety function have been studied. In contrast we examine the preliminary-announcement and indication function to inform the forthcoming operation of the robot for surrounding people before it moves in that manner. It is difficult for people to analogize the next operation of

A part of this research has supported by the following foundations and here we express gratitude; SUZUKI Foundation and FANUC FA & Robot Foundation both in 2001 fiscal year, TATEISHI Science and Technology Foundation and MITSUTOYO Association for Science and Technology both in 2005 fiscal year, and CASIO Science Promotion Foundation in 2006 fiscal year.

T. Matsumaru is with Faculty of Engineering and Graduate School of Engineering, Shizuoka University, Hamamatsu, 432-8561, Japan
ttmatum@ipc.shizuoka.ac.jp

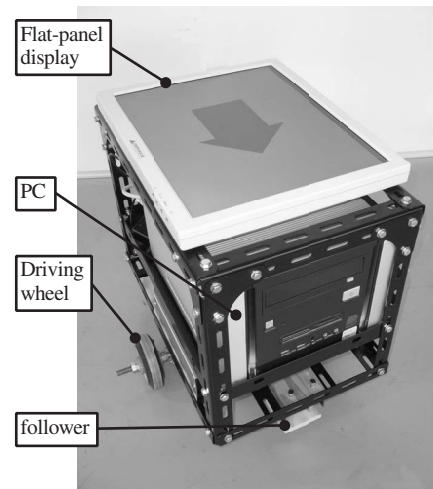

Fig. 1. Overview of PMR-6

a robot only from its outward appearance if there is no special treatment because the robot is a technical artifact. The function to preliminarily-announce and indicate the next operation is necessary when a robot operates in the human-coexisting environment. This is because the characteristic and the ability of each robot are various and those are depending on each individual so that people cannot keep in mind them as commonsense. This research examines the communication method except sound or voice. If sound or voice is used, information can be transmitted to all surrounding people at once. But information will be forcedly transmitted also to the person who does not desire it. Sound or voice breaks the silence or quietness of the surroundings in public spaces and it disturbs or interrupts the person who does not like it.

II. PRELIMINARY-ANNOUNCEMENT AND INDICATION OF FORTHCOMING OPERATION OF MOBILE ROBOT

A. Relating research and previous research

Most of the previous research on nonverbal interface between a person and the machine is concerning the transmission of information in the direction from a person to the machine. For instance, aiming at the communication with some system or the operation of some equipment, many researches on image data processing of the body language or hand gesture [1], [2], [3] and the facial expression or glance [4], [5], [6] have been done to assume the person's action and intention. Moreover there have been some researches on analyzing one's feelings at that time based on the

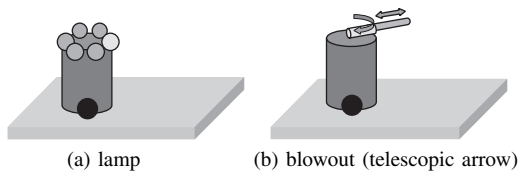

Fig. 2. Indicating the state just after the moment

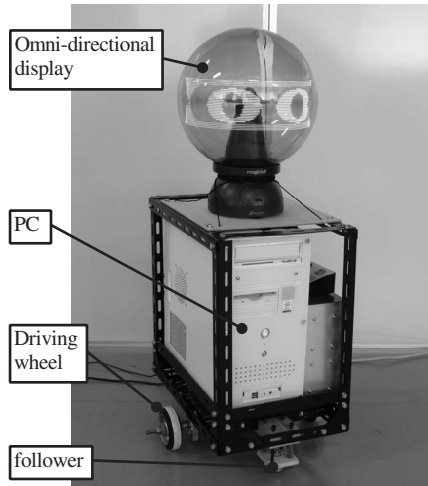

Fig. 3. Overview of PMR-2

psychological knowledge about the human facial expression [7], [8]. Compared with them, there are few researches on the transmission of information in the direction from the machine to a person especially about the next operation of robotic systems. As a multifunctional interface with display, Digital Desk [9] is well known and several trial systems have been reported [10], [11], [12], [13]. There are also some researches on teleoperation or teaching of robotic systems using multimedia display [14], [15] or PDA (Personal Digital Assistant) [16], [17]. Concerning the indication of the internal state of robot, the monitor screen to display the remaining amount of battery, the internal temperature, etc. are tried in a mobile robot [18]. As the expression of the forthcoming operation of robot, the projection function to common space between the manipulator and a person is proposed [19], and the experiments on the industrial robot that installs multiple LEDs at the tip aiming to support meals for physically handicapped people have been reported [20], [21].

B. Method to previously-announce and indicate the forthcoming operation using a flat-panel display

We may use a simple and plain new means for robot to transmit information to people other than the same method as people. But it must be easy for people to analogize, understand, and judge from general commonsense. We think two kinds of information, the speed of motion and the direction of motion, are important on operation. It is because this research aims the mobile robot which moves on a two-dimensional plane. We have proposed two types of method, (1) preliminary-announcement and indication of the state just

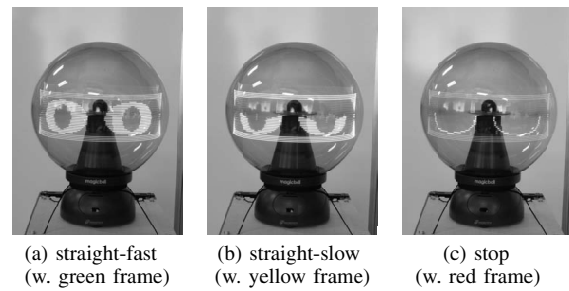

Fig. 4. Speed of motion: degree on opening/closing the eyeball

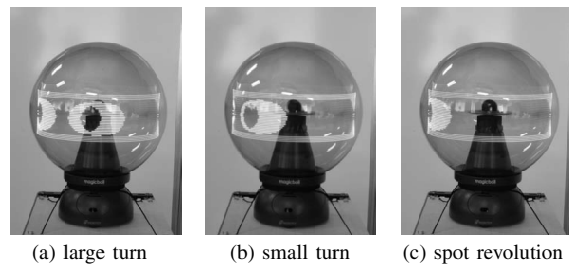

Fig. 5. Direction of motion: position of the eyeball

after the present and (2) preliminary-announcement and indication of the operations from the present to some future time continuously. And we have devised four kinds of method, (a) lamp, (b) blowout (telescopic arrow), (c) light-ray, and (d) projection [22]. The effect and the timing of preliminary-announcement have been evaluated and examined using the computer simulation [23], [24], [25], [26].

The blowout (telescopic arrow) method is developed after the lamp method in type (1), announcing and indicating the state just after the present.

1) *Lamp Method*:: In the lamp method (Fig. 2(a)), several lamps are arranged on the upper surface of the mobile robot. The direction of motion is announced by turning on the lamp along which the robot is going to move. Blinking rates or different colors of lamp can be used to indicate the speed of motion. In the robot PMR-2 (Fig. 3) that makes the lamp method an embodiment, a commercial omni-directional display, magicball (R), is used and it is set on the two-driving-wheel type mobile unit [27]. The basis of design shown on the display is made 'eyeball' for ordinary people to make easy to analogize the meaning from commonsense even at first sight. The sight line is one of the clues for people to estimate the other's action and intention on each other. We also want to make the robot friendly for people. The target motion of the robot is three kinds at the speed (high speed, low speed and stop) and four kinds in the direction (going straight, large-turn, small-turn, and spot revolution). The speed of motion of the robot is expressed as the degree on opening/closing the eyeballs. That is, the eyeballs are fully opened, half opened, and closed in response to high-speed, low-speed, and stop, respectively (Fig. 4). The direction of motion of the robot is indicated as the position of the eyeballs. That is, the eyeballs are positioned at 0, 30, 60, and 90 deg from the front face in response

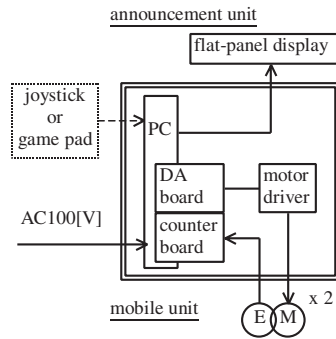

Fig. 6. System configuration of PMR-6

to going straight, large-turn, small-turn, and spot revolution, respectively (Fig. 5). The magicball is a spherical object so that the front face which is the criterion to indicate the direction of motion is unintelligible. Accordingly we set the fixed frame with colors that covers the viewing area except the foreside where the eyeballs are displayed. The color of the frame is switched according to the speed of motion in reference to the signal colors: in green at high speed, in yellow at low speed, and in red at stop. The eyeballs corresponding to the operation are displayed at 1.5 s before the actual operation based on the result of the simulation study [26].

2) *Blowout Method*:: The blowout is a toy or a party gadget. Blowing air into the cylinder extends the blowout, and stopping blowing makes it rewind from top to origin. In the blowout method (Fig. 2(b)), the blowout is put on a turntable and those are set up on the mobile robot [28]. The speed of motion and the direction of motion of the robot are expressed as the total length and the tip direction of the blowout respectively. The result of the comparative study between the lamp and the blowout in simulation shows that both the change in shape more than the color variation and the continuous changing rather than the discrete changing convey information easily and seem to be comprehensible [26]. In the robot PMR-6 that has made for trial to realize the blowout method, a flat-panel display is used instead of some mechanism that imitates the actual blowout (telescopic arrow). The modification or improvement of a mechanism is difficult once it is manufactured. The display is useful to test various compositions, shapes and colors only with changing the content to display.

III. PMR-6, MOBILE ROBOT WITH PRELIMINARY-ANNOUNCEMENT FUNCTION USING FLAT-PANEL DISPLAY

The developed mobile robot PMR-6 (Fig. 1) consists of the announcement unit with the mobile unit (Fig. 6, Table I). LCD is adopted as the announcement unit. PC to control is equipped but the power (AC100 V) is supplied from the outside because PMR-6 is assumed to be a functional prototype of the preliminary-announcement and indication function. Software is developed on Windows 2000 using Microsoft Visual C++ 6.0. The composition of the program

TABLE I
SPECIFICATIONS OF PMR-6

Item	Specification
Size (incl. protruding portion)	D470 × W480 × H440 mm
Weight	22.0 kg
Max. speed (translation)	180.0 mm/s
(rotation)	20.7 deg/s

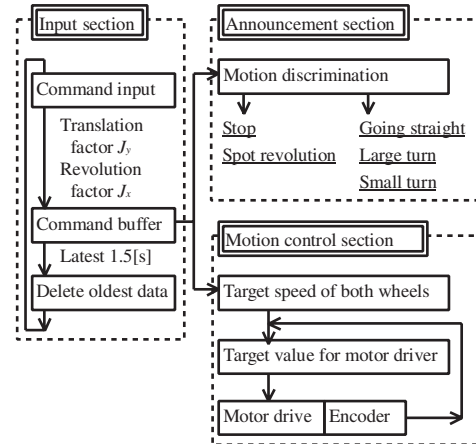

Fig. 7. Three sections in program

is invariant even if the robot moves along pre-defined route or it is operated manually in real time. When the program is started, the timer is set and three threads are started: the instruction input, the movement (driving wheel) control, and the announcement display (Fig. 7). These threads work in 50 ms at the same time. In PMR-6 (flat-panel display) as in PMR-2 (omni-directional display), the content corresponding to operation is displayed at 1.5 s before the actual operation, in reference to the result of the simulation study [26]. When a certain instruction is input, the operation according to the instruction is displayed on the screen immediately, and the instruction is actually executed at 1.5 s after the input.

A. Instruction Input

The robot takes the revolution instruction J_x and the translation instruction J_y in every 50 ms. The value is from -1000 to $+1000$. A joystick, the Side Winder Force Feedback 2 (Microsoft Co.), or a game pad, the JC-U912BK (Elecom Co.), is used as the input device. The robot moves forward when knocking down the stick forward (minus value is obtained) in order to match the robot's motion to the operator's feeling. The dead band is installed around zero point when taking each instruction value.

B. Movement (Driving Wheel) Control

The acquired speed instruction value is always accumulated for 1.5 s in the instruction value buffer (the array of 30 pieces for instruction value, J_x and J_y , in every 50 ms). And the instruction value at 1.5 s before that time is used to calculate the target value to control the driving wheels. Due to the two-driving-wheel type mobile unit, the translation and the revolution are controlled in the rotation ratio of two

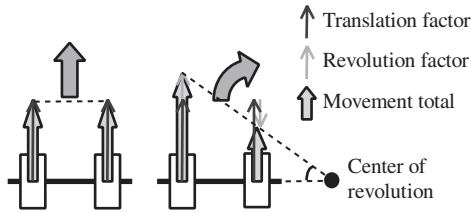

Fig. 8. Motion control

driving wheels on both sides. The movement of the robot is controlled with dividing the maximum speed, that can be achieved by rotating the driving wheel, into the translation factor and the revolution factor (Fig. 8). Both the distance that the robot should proceed during the control cycle (50 ms) and the rotation angle that each wheel should rotate during the meantime can be calculated. Therefore the target speeds of two wheels, V_1 and V_2 , are decided from the instruction value, J_x and J_y .

C. Announcement Display

The state of operation after 1.5 s is shown on the display set up upward on the mobile unit. The states of operation to display are roughly divided into three: 'going forward or backward', 'spot revolution', and 'stop'. The expression is discrete: three kinds at the speed (high-speed, low-speed, and stop) and four kinds in the direction (going straight, large-turn, small-turn, and spot revolution), although both the speed of motion and the direction of motion can be controlled continuously. This is because the comparison between PMR-6 (flat-panel display, arrow) and PMR-2 (omni-directional display, eyeball) is emphasized on the evaluation about the intelligibility of the preliminary-announcement and indication function. The magicball in PMR-2 takes 0.5 s to switch the contents to display. Consequently, the condition to evaluate is aligned to the discrete expression at 1.5 s before the actual operation.

The basis of design shown on the display is made 'arrow', imitating the real blowout which is like a telescopic arrow. The arrow sign is commonly used when pointing the direction. So we think the arrow is comparatively comprehensible as a sign to express the movement even when looking at for the first time. The speed of motion of the robot is expressed as the size (length and width) and color (based on traffic signal) of the arrow. That is, the large arrow in green, the small arrow in yellow, and the characters in red show high-speed, low-speed, and stop, respectively. The direction of motion of the robot is described with the curved condition of the arrow. That is, the straight arrow, the curved arrow, the swerved arrow, and the rounded arrow indicate going straight, large-turn, small-turn, spot revolution, respectively. These contents are presented on the display at 1.5 s before the actual operation. There are two steps to display the forthcoming operation.

1) *Distinction of the state of operation*:: First the state of operation (the contents to display, inside row in Table II)

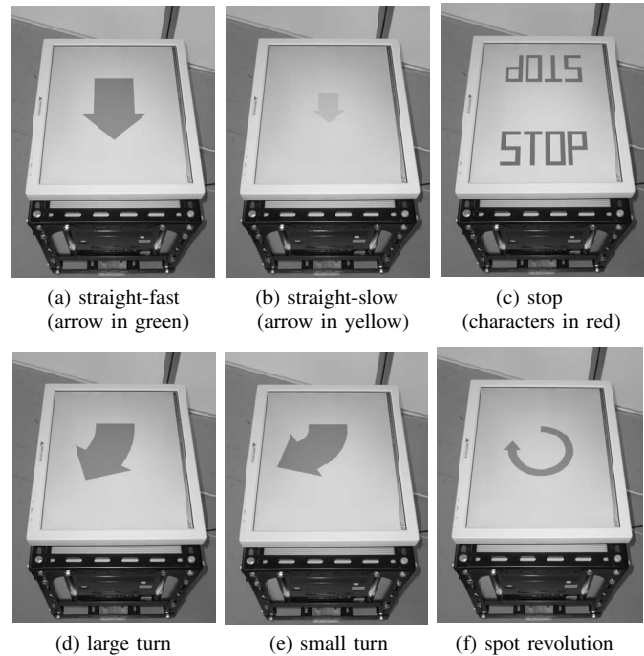

Fig. 9. Displayed sign (on white background)

is distinguished from the combination of speed instructions (J_x and J_y), even if the robot moves along pre-defined route or it is operated manually in real time.

2) *Content to display*:: The content corresponding to the state of operation which is classified in 1) is displayed (right row in Table II). In the case of 'going forward/backward' the arrow is displayed as either fat-long-green arrow (Fig. 9(a)) or thin-short-yellow arrow (Fig. 9(b)) according to the speed of motion. One of them, straight arrow (Fig. 9(a)), curved arrow (Fig. 9(d)), or swerved arrow (Fig. 9(e)), is displayed according to the direction of motion. In the case of 'spot revolution', the rounded arrow (Fig. 9(f)) is displayed, either in fat-green or in thin-yellow according to the speed of motion. It is either in clockwise or in counter-clockwise according to the direction of motion. In the case of 'stop' the characters of STOP (Fig. 9(c)) are displayed in red both in forward-looking and in backward-looking.

IV. QUESTIONNAIRE EVALUATION

A. Purpose

The questionnaire evaluation is aimed that various subject persons evaluate the intelligibility and understandability of the preliminary-announcement and indication function of the future speed of motion and the future direction motion using the flat-panel display. Especially we pay attention whether the evaluation of intelligibility will differ depending on gender or age. It is also assumed the chance to widely look for the opinion or comment on the research topic.

B. Method

The developed four robots, the eyeball robot PMR-2 (the eyeballs are displayed on the omni-directional display [27]),

TABLE II
MOTION DISCRIMINATION

Input		Motion (speed) (direction)	Display contents (size, color) (orientation)
Translation factor J_y	Revolution factor J_x		
0	0	Stop	STOP character (red) (for/back)
0	$0 < J_x < 500 $	spot revolution (slow) (right/left)	rounded arrow (thin, yellow) (right/left)
0	$ 500 < J_x < 1000 $	spot revolution (fast) (right/left)	rounded arrow (thick, green) (right/left)
$0 < J_y < 500 $	0	going straight (slow) (fore/back)	straight arrow (thin-short, yellow) (fore/back)
$0 < J_y < 500 $	$0 < J_x < 500 $	large turn (slow) (fore/back, right/left)	curved arrow (thin-short, yellow) (fore/back, right/left)
$0 < J_y < 500 $	$ 500 < J_x < 1000 $	small turn (slow) (fore/back, right/left)	swerved arrow (thin-short, yellow) (fore/back, right/left)
$ 500 < J_y < 1000 $	0	going straight (fast) (fore/back)	straight arrow (thick-long, green) (fore/back)
$ 500 < J_y < 1000 $	$0 < J_x < 500 $	large turn (fast) (fore/back, right/left)	curved arrow (thick-long, green) (fore/back, right/left)
$ 500 < J_y < 1000 $	$ 500 < J_x < 1000 $	small turn (fast) (fore/back, right/left)	swerved arrow (thick-long, green) (fore/back, right/left)

the arrow robot PMR-6 (the arrow is displayed on the flat-panel display), the light-ray robot PMR-1 (the light-ray from the laser pointers is reflected on the mirror and the schedule route is draw on the running surface [29]), and the projection robot PMR-5 (the projection equipment can project various information on the running surface [30]), were exhibited to the 2005 International Robot Exhibition (sponsoring: Japan Robot Association and Nikkan Kogyo Shimbun Ltd., from 30 Nov. to 03 Dec. at Tokyo International Exhibition Hall). It was under a comparatively bright lighting condition in facilities. This is the same situation where the preliminary-announcement function of the robot is assumed to be used at the first onset. We requested visitors to answer the questionnaire as a rudimentary trend review and opinion research.

C. Procedure

We asked the respondents look freely at the moving four robots while previously-announcing and indicating the forthcoming operation, while/after explaining the background and purpose, the proposed method to display the forthcoming operation, the total composition of the robots, etc. The robots were manually operated in real time and various pre-defined routes were also driven during the demonstration/experimentation. The questions were set as follows.

Please circle a suitable place.

- ◇ The future speed of motion is previously announced with the size/color of the arrow shown on the display.
It is (unintelligible) 1 - 2 - 3 - 4 - 5 (intelligible).
- ◇ The future direction of motion is previously announced with the direction of the arrow shown on the display.
It is (unintelligible) 1 - 2 - 3 - 4 - 5 (intelligible).

Please fill in your opinion or comment to PMR-6 freely.

Especially we asked the respondents the intelligibility might be evaluated not relatively among four robots but absolutely in own sense. In the question concerning PMR-2, the respondent answered the question replaced 'size/color of the arrow' by 'degree on opening/closing the eyeball' at the

TABLE III
RESPONDENTS

gender	age								total
	10-	20-	30-	40-	50-	60-	70-	no	
male	6	39	43	35	35	16	2	9	185
female	1	6	3	3	0	0	0	3	16
no	0	3	4	1	0	0	0	3	11
total	7	48	50	39	35	16	2	15	212

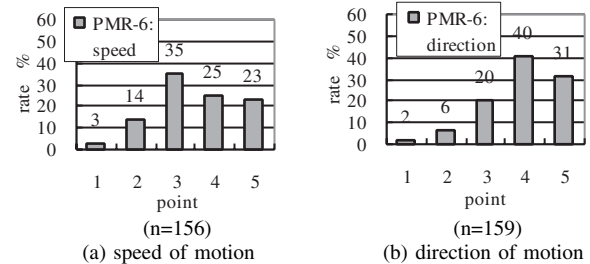

Fig. 10. Evaluation point (PMR-6, flat-panel display)

speed of motion. And it is replaced 'direction of the arrow' by 'position of the eyeball' at the direction of motion.

D. Result and Discussion

We obtained about 200 replies in four days. The composition of respondents according to gender and age is shown in Table III. The respondent's total rate in number to the evaluation point is summarized both about the speed of motion and about the direction of motion in Fig. 10. The average and standard deviation of the evaluation point are shown in Table IV.

In PMR-6, the total average of the evaluation point about the speed of motion is 3.56, so it is evaluated comparatively intelligible. The total average of the evaluation point about the direction of motion is 3.98, so it is evaluated roughly intelligible. On the other hand in PMR-2, the total average of the evaluation point are 2.87 and 3.37 about the speed of

TABLE IV
EVALUATION POINT

	PMR-6 (flat-panel)		PMR-2 (omni-directional)	
	speed	direction	speed	direction
total	3.56 (1.06)	3.98 (0.95)	2.87 (1.23)	3.37 (1.13)
male	3.53 (1.06)	3.98 (0.96)	2.86 (1.21)	3.38 (1.12)
female	3.79 (1.16)	4.04 (0.96)	3.04 (1.42)	3.35 (1.18)
10-19	4.00 (1.55)	4.50 (0.84)	3.00 (1.15)	4.14 (1.07)
20-29	3.39 (1.07)	3.96 (1.03)	2.57 (1.19)	3.34 (1.16)
30-39	3.65 (1.13)	3.97 (0.96)	2.97 (1.45)	3.17 (1.24)
40-49	3.32 (0.83)	3.66 (0.84)	2.54 (1.09)	3.15 (1.03)
50-59	3.86 (1.03)	4.35 (0.89)	3.08 (1.04)	3.59 (1.15)
60-	3.50 (1.00)	3.80 (0.82)	3.67 (1.11)	3.80 (0.73)

average (standard deviation)

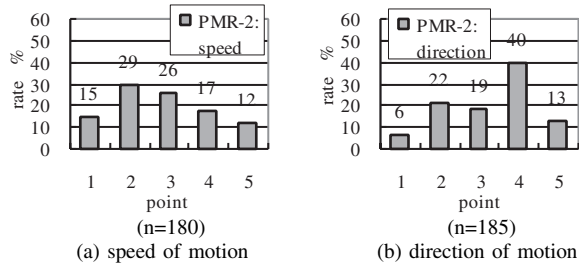

Fig. 11. Evaluation points (PMR-2, omni-directional display)

motion and the direction of motion, respectively (Fig. 11). When the difference of two groups' mean values is given official approval, a significant difference in the level of 5% is admitted both on the speed of motion and on the direction of motion: (speed) $p = 7.18E - 08$, $t = 5.51$, $df = 334$, (direction) $p = 1.14E - 07$, $t = 5.42$, $df = 342$. The result that the evaluation to PMR-2 is lower than that to PMR-6 leads the following remarks. The eyeball expression on omni-directional display in PMR-2 requires the translation and it admits various interpretations between the sign and the motion to people who look at it. The arrow expression on flat-panel display in PMR-6 is more direct and intuitive without translation or interpretation for people. The blowout method (realized as PMR-6) developed the lamp method (embodied in PMR-2). Consequently the result of questionnaire evaluation shows the improvement on intelligibility between PMR-2 and PMR-6 as we aimed.

The distribution in evaluation point depending on gender is shown in Fig. 12. The females were extremely small number compared with the males, and the significant difference cannot be confirmed in the mean value. However the tendency is compared to get some suggestive information. About the speed of motion, the females evaluate higher than the males on the whole (male: 3.53, female: 3.79) and the distribution in evaluation point is shifted high. About the direction of motion, the average evaluation point is almost equal (male: 3.98, female: 4.04) and the distribution in evaluation point has similar tendency between the males and the females. The females' evaluation about the speed of motion is not singular because the same distribution tendency is observed in the direction of motion. The definite reason is uncertain but it suggests the females accept the change in size of the arrow

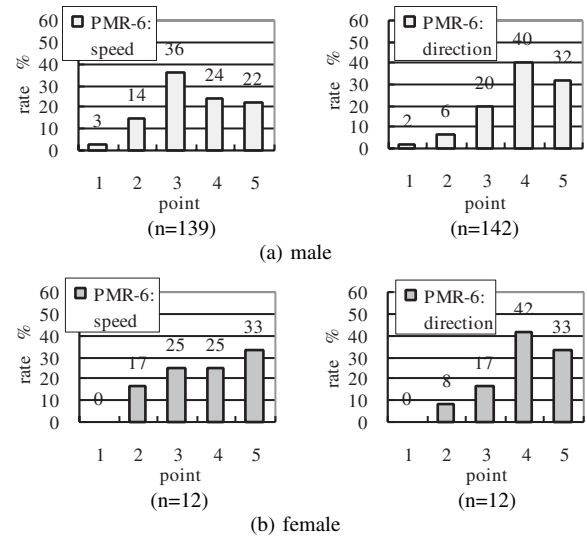

Fig. 12. Gender-segregated result

and the change in color based on traffic signal in response to the speed of motion more favorably than the males.

The distribution in evaluation point according to age is shown in Fig. 13. Because the number of respondents is small on the younger and the elderly, the evaluation point is counted in three groups, the younger age (teens and twenties), the middle age (thirties and forties), and the upper age (fifties, sixties, and above). Significant difference by the level of 5% is largely admitted only between the middle age and the upper age about the direction of motion: $p = 0.056$, $t = 1.94$, $df = 71$. About the speed of motion, the distribution on the upper age stands out and it has two peaks. One peak group moderately evaluates it as well as most of the middle age. Another peak group evaluates it higher than the younger age. About the direction of motion, the tendency of the distribution is almost the same between the younger age and the upper age, and those are overall higher than that on the middle age.

E. Free Space to Fill Up

Various opinions were obtained in the free space to fill up. Those are classified according to the details, and the examples are listed and considered in the following.

1) *Presentation Technique of Information*:: We received a lot of friendly opinions.

- It is comprehensible.
- Because it is a clear sign, it is comprehensible.
- It is intuitively comprehensible.

2) *Flat-panel Display*:: There are a lot of affirmative opinions on using a flat-panel display.

- The presentation is clear and comprehensible because it is a display.
- It is easy to see. It seems to be able to inform a lot of other information.

There are some opinions that LCD might be difficult to see without approaching the robot because the viewing angle is limited even though we selected a wide-viewing-angle type.

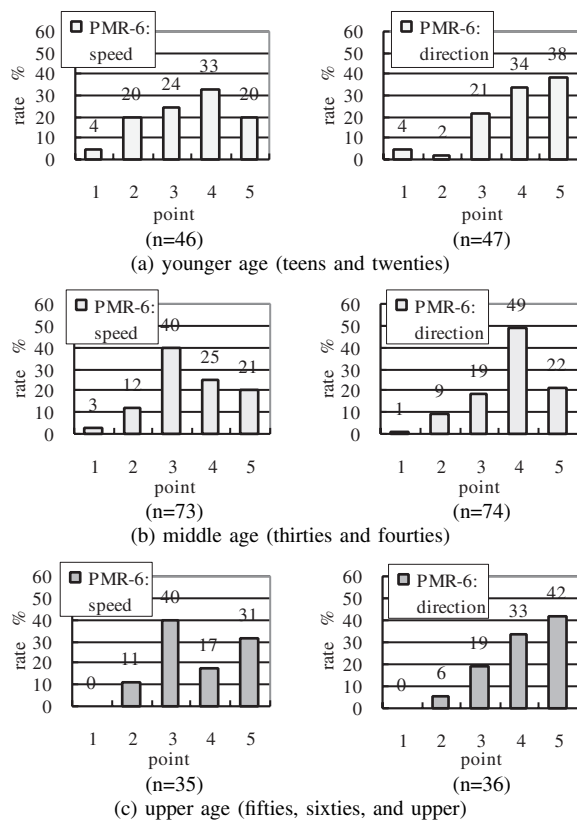

Fig. 13. Age-specific result

- Sometimes it is not easy to see due to the directivity of the liquid crystal.
- I can't see it unless in the vicinity.
- It is not easy to understand unless looking down from the above.

The position to look at easily is limited on LCD because the surrounding brightness may influence. We also received an opinion that the viewability in hardware should entrust to the specialists because the display technology keeps on improving with the popularization of high-quality and thin-model television. We would expect the research and development and the commercialization of new type display in the future.

3) *Configuration*:: We received the assignments on restricting the design of the robot when the display is set up on the upper surface.

- It will become a restriction for design of the robot.
- The shortcoming is some space to set up the display equipment is necessary.
- It will become a restriction on size and height of the robot if we have to see the upper surface of the robot's main body.

There are other opinions that we should devise on the position and the direction to install the display. For example, we might install two or more displays along the sides of the robot. However it is like the omni-directional display.

4) *Expression with Arrow*:: There are various opinions especially on the speed of motion.

- More explanation is necessary to express the speed of motion only by some mark. More comprehensible mark is better and indispensable.
- It is difficult to understand the correspondence of the length of arrow with the speed of robot without learning.
- I cannot understand whether the length of arrow is long or short until becoming familiar to the expression.

As respondents pointed out it is impossible to guess the absolute speed of the robot accurately from the very beginning. People can judge and recognize the forthcoming operation of the robot only after looking at various movements of the robot for a while and with understanding the relationship between the displayed contents and the forthcoming operation. We think the function might be used like this at first.

We tried to make the expression become easy for people to analogize from ordinary commonsense as much as possible, for instance, by using the arrow expression and the colors of traffic signal. There are both opinions, being sufficiently understandable and being lacking in consideration.

- I can understand intuitively. It is because it uses some idea common with the traffic sign. The aspect to make common with something around is important.
- It will be more easily understood if it will become the rule like the traffic sign.

We think the trial and error is necessary for the method and content of the expression. Various expressions should be presented to the general public and many opinions and advices should be acquired. Then some expression will become like commonsense for most of the people.

There are also following opinions and remarks on displaying the speed of motion by using the arrow. We will refer in order to improve the expression.

- The starting point of the drawn arrow should be fixed rather than being displayed at the center of the screen. More ingenuity is necessary on the length of the arrow.
- It will become more comprehensible if the arrow moves like animation.
- The tachometer form is more comprehensible rather than the level gauge form.

There is no comment on the timing to announce, whether it is too early or too late, which was set at 1.5 s before the actual motion as mentioned in III-C. There is also no comment on that we used not the sign but the characters to express 'stop' such as discomfort.

A certain amount of appreciation has been obtained on the solution we proposed. More improvement and development are necessary and we will advance further in reference to the obtained opinions.

V. CONCLUSION AND FUTURE WORKS

This paper discussed the mobile robot PMR-6 with the new function in which the forthcoming operation is preliminary-announced and indicated to the surrounding people by using a flat-plane display. The future speed of motion is expressed as the size and color of the arrow. The future

direction of motion is described with the curved condition of the arrow.

In the questionnaire evaluation the robots were evaluated during/after the respondents looked at the robot and they were explained the purpose and method to announce. The method of preliminary-announcement and indication of the forthcoming operation is preferable to be judged and understood from commonsense even at first sight. So the evaluation by subject persons without advance knowledge is one of the future works.

The automatic cleaner (domestic cleaning autonomous robot) that is marketed and becoming popular might be an effective application in the form that a flat-panel display is equipped on the robot like PMR-6. It will be no problem when the robot moves along the pre-defined route. Even if the route is decided on site, like automatic cleaner, it doesn't matter from the viewpoint of accomplishment of the task. Because the route is preliminary-announced and displayed to surrounding people then the robot actually moves like that after some fixed period. However in the case of the manual operation in real time, like automobiles, the maneuverability for operator will become worse. It is because the time-delay will be always inserted between the instruction and the execution. So in that case we have to devise the method that the robot executes the instruction from operator in real time both with forecasting the operator's next operation from the operational record and the environmental condition and with indicating the forecasted operation to surroundings. In addition the future work also includes the examination of the method to deal with the case that the operator does contradictory operation to the forecasted operation and the case that robot does sudden autonomous operation to secure safety like stopping, with the method to forecast the operator's next operation.

VI. ACKNOWLEDGMENTS

The author gratefully acknowledge the contribution of the following laboratory members on this research project: Yu Hoshihara, Yasuhiro Miyata and Shinji Hiraiwa.

REFERENCES

- [1] E. Ueda, et al.: "Hand Pose Estimation for Vision Based Human Interface", *Proc. 10th IEEE Int. Workshop on Robot and Human Communication (ROMAN 2001)*, 473/478, (2001).
- [2] L. Bretzner, et al., "Hand gesture recognition using multi-scale colour features, hierarchical models and particle filtering", *Proc. 5th IEEE Int. Conf. on Automatic Face and Gesture Recognition*, 405/410, (2002).
- [3] H. Fei and I. Reid: "Dynamic Classifier for Non-rigid Human motion analysis", *British Machine Vision Conf.*, 118, (2004).
- [4] Y. Matsumoto, et al.: "Development of Intelligent Wheelchair System with Face and Gaze Based Interface", *Proc. 10th IEEE Int. Workshop on Robot and Human Communication (ROMAN 2001)*, 262/267, (2001).
- [5] Y. Kuno, et al.: "Look where you're going: A robotic wheelchair based on the integration of human and environmental observations", *IEEE Robotics and Automation Magazine*, 10(1), 26/34, (2003).
- [6] T. Ohno and N. Mukawa: "A Free-head, Simple Calibration, Gaze Tracking System That Enables Gaze-Based Interaction", *Proc. Eye Tracking Research & Application Symposium 2004 (ETRA 2004)*, 115/122, (2004).
- [7] Y. Liu, et al.: "Human facial asymmetry for expression-invariant facial identification", *Proc. Fifth IEEE Int. Conf. on Automatic Face and Gesture Recognition (FG'02)*, 208/214, (2002).
- [8] Y.-L. Tian, et al.: "Facial expression analysis", in S.Z. Li and A.K. Jain (ed.): "Handbook of face recognition", Springer, (2005).
- [9] P.D. Wellner: "The DigitalDesk Calculator: Tactile Manipulation on a Desk Top Display", *Proc. ACM Symp. on User Interface Software and Technology (UIST '91)*, 27/33, (1991).
- [10] H. Koike, et al.: "Integrating paper and digital information on EnhancedDesk: a method for realtime finger tracking on an augmented desk system", *ACM Trans. on Computer-Human Interaction (TOCHI)*, 8(4), 307/322, (2001).
- [11] J. Rekimoto: "SmartSkin: An Infrastructure for Freehand Manipulation on Interactive Surfaces", *Proc. SIGCHI conf. on Human factors in computing systems (CHI '02)*, 113/120, (2002).
- [12] J. Patten, et al.: "Sensetable: A Wireless Object Tracking Platform for Tangible User Interfaces", *Proc. SIGCHI conf. on Human factors in computing systems (CHI '01)*, 253/260, (2001).
- [13] B. Piper, et al.: "Illuminating Clay: A 3-D Tangible Interface for Landscape Analysis", *Proc. SIGCHI conf. on Human factors in computing systems (CHI '02)*, 355/362, (2002).
- [14] T. Matsui and M. Tsukamoto: "An Integrated Teleoperation Method for Robots using Multi-Media-Display", *J. Robotics Society of Japan*, 6(4), 301/310, (1988).
- [15] M. Terashima and S. Sakane: "A Human-Robot Interface Using an Extended Digital Desk Approach", *J. Robotics Society of Japan*, 16(8), 1091/1098, (1998).
- [16] H.K. Keskinpala, et al.: "PDA-Based Human-Robotic Interface", *Proc. 2003 IEEE Int. Conf. on Systems, Man, and Cybernetics*, 3931/3936, (2003).
- [17] T.W. Fong, et al.: "PdaDriver: A Handheld System for Remote Driving", *11th Int. Conf. on Advanced Robotics 2003*, 88/93, (2003).
- [18] T. Ogata and S. Sugano: "Emotional Communication between Humans and the Autonomous Robot WAMOEBEA-2 (Waseda Amoeba) which has the Emotion Model", *JSME Int. J., Series C*, 43(3), 586/574, (2000).
- [19] Y. Wakita, et al.: "Information Sharing via Projection Function for Co-existence of Robot and Human", *Autonomous Robots*, 10(3), 267/277, (2001).
- [20] Y. Kawakita, et al.: "Previous notice method of robotic arm motion for suppressing threat to human", *Japanese J. Ergonomics*, 37(5), 252/262, (2001).
- [21] A. Hagiwara, et al.: "Previous Notice Method of Robotic Arm Motion for Suppressing Threat to Human", *J. Robotics Society of Japan*, 21(4), 67/74, (2003).
- [22] T. Matsumaru and K. Hagiwara: "Method and Effect of Preliminary-Announcement and Display for Translation of Mobile Robot", *Proc. 10th Int. Conf. on Advanced Robotics (ICAR 2001)*, 573/578, (2001).
- [23] T. Matsumaru and K. Hagiwara: "Preliminary-Announcement and Display for Translation and Rotation of Human-Friendly Mobile Robot", *Proc. 10th IEEE Int. Workshop on Robot and Human Communication (ROMAN 2001)*, 213/218, (2001).
- [24] T. Matsumaru, et al.: "Examination by Software Simulation on Preliminary-Announcement and Display of Mobile Robot's Following Action by Lamp or Blowouts", *2003 IEEE Int. Conf. on Robotics and Automation (2003 IEEE ICRA)*, 362/367, (2003).
- [25] T. Matsumaru, et al.: "Simulation on Preliminary-Announcement and Display of Mobile Robot's Following Action by Lamp, Party-blowouts, or Beam-light", *IEEE/ASME Int. Conf. on Advanced Intelligent Mechatronics (AIM 2003)*, 771/777, (2003).
- [26] T. Matsumaru, et al.: "Examination on a Software Simulation of the Method and Effect of Preliminary-announcement and Display of Human-friendly Robot's Following Action", *Trans. Society of Instrument and Control Engineers*, 40(2), 189/198, (2004).
- [27] T. Matsumaru, et al.: "Mobile robot with eyeball expression as the preliminary-announcement and display of the robot's following motion", *Autonomous Robots*, 18(2), 231/246, (2005).
- [28] T. Matsumaru and Y. Terasawa: "Preliminary Announcement and Display for Human-Friendly Mobile Robot", *Preprints IFAC Workshop on Mobile Robot Technology*, 226/231, (2001).
- [29] T. Matsumaru, et al.: "Mobile Robot with Preliminary-Announcement Function of Following Motion using Light-ray", *2006 IEEE/RSJ Int. Conf. on Intelligent Robots and Systems (IROS 2006)*, 1516/1523, (2006).
- [30] T. Matsumaru: "Mobile Robot with Preliminary-announcement and Display Function of Following Motion using Projection Equipment", *15th IEEE Int. Symposium on Robot and Human Interactive Communication (RO-MAN 06)*, 443/450, (2006).