

# A Hybrid Actuation Approach for Human-Friendly Robot Design

Dongjun Shin<sup>1</sup>, Irene Sardellitti<sup>1,2</sup>, Oussama Khatib<sup>1</sup>

<sup>1</sup>Artificial Intelligence Laboratory, Stanford University, Stanford, CA 94305  
{djshin, ok}@robotics.stanford.edu

<sup>2</sup>ARTS Lab., Scuola Superiore Sant'Anna, 56127 Pisa, Italy  
irene@arts.sssup.it

**Abstract**—Safety is a critical characteristic for robots designed to operate in human environments. This paper presents the concept of hybrid actuation for the development of human-friendly robotic systems. The new design employs inherently safe pneumatic artificial muscles augmented with small electrical actuators, human-bone-inspired robotic links, and newly designed distributed compact pressure regulators. The modularization and integration of the robot components enable low complexity in the design and assembly. The hybrid actuation concept has been validated on a two-degree-of-freedom prototype arm. The experimental results show the significant improvement that can be achieved with hybrid actuation over an actuation system with pneumatic artificial muscles alone. Using the Manipulator Safety Index (MSI), the paper discusses the safety of the new prototype and shows the robot arm safety characteristics to be comparable to those of a human arm.

## I. INTRODUCTION

### A. Background

Commercial robotic manipulators are currently deployed in restricted environments where the interaction between human and robot is strictly regulated. The new emerging applications of robotics are increasingly bringing robots into proximity with humans. To closely work and interact with humans, the new generation of robots must be inherently safe and at same time highly capable systems. Safety and performance are typically competing objectives. The safety issue primarily involves mitigating impact load from unexpected collisions between robot and human. Robots that employ compliant drive trains, which include compliant actuators, are inherently safe since they do not produce the large impact loads associated with high impedance designs. However, compliance in the drive train significantly limits the robot's performance because it reduces control bandwidth, due to structural resonance [1]. Several approaches address this limitation. Among them are the series elastic actuation (SEA) approach [2], the parallel-coupled micro-macro actuation (PaCMA) approach [3], and the variable stiffness transmission (VST) approach [4].

Most robots exploit high stiffness to achieve high performance. They utilize high gear reduction ratio to compensate for the lack of the power of electrical motors. Unfortunately, this results in robots that have high effective inertia, since the inertia is proportional to the square of the gear reduction ratio. High stiffness and inertia can generate large impact force in a collision. While conventional robots are able

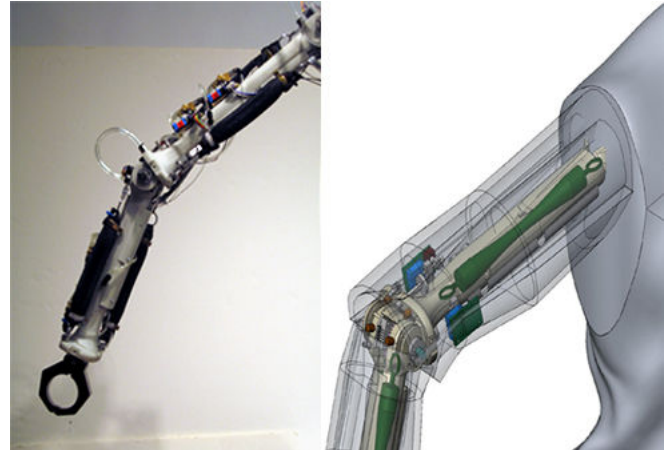

Fig. 1. Stanford Human Safety Robot

to deal with external impact forces within their control bandwidth, they can display unexpectedly high impedance outside their bandwidth. Although safety can be achieved by the strict limitation of the power and velocity of high performance manipulators, as is done in medical devices, an innovative scheme must be developed to make general-purpose robots safe in human environments.

### B. Distributed Macro-Mini Concept (DM<sup>2</sup>)

In recent years, our effort in human-friendly robotic systems has focused on the development of actuation systems that can provide robots with the characteristics of both safety and performance. This effort has led to the development of the Distributed Macro-Mini (DM<sup>2</sup>) actuation concept [6]. This study has involved the development and construction of several prototypes. These include a two-DOF arm [5] and a two-arm Human-Friendly Robot (HFR) [1]. These prototypes provided us with the experimental platforms for the validation of the DM<sup>2</sup> concept. The results demonstrated an order of magnitude increase in safety and a significant increase in control bandwidth, leading to excellent performance in motion and force control. As the name implies, the DM<sup>2</sup> concept employs a pair of actuators, connected in parallel and distributed to different locations on the manipulator. The effective inertia of the overall manipulator is substantially reduced by both isolating the reflected inertia of the actuator

and greatly reducing the overall weight of the actuators carried by the manipulator. For the high frequency actuation, very low impedance is achieved by using a small low-inertia torque motor connected to the manipulator through a low friction, low reduction cable transmission. For the low frequency actuation, low impedance is achieved by using a series elastic actuator [5]. The heavy and bulky low frequency actuator (Macro) is relocated from the arm to the base, i.e., torso, while the high frequency actuator (Mini) is still collocated at the joint. This results in reducing the weight of the moving arm drastically, while the on-joint mini actuator increases the control bandwidth and fast dynamics regardless of the effect of the elastic coupling.

However, this robot presents many practical challenges in terms of design and assembly. In addition, due to the low force-to-weight ratio of electrical motors, the system needs heavy and bulky motors as well as large pulleys to meet the joint torque requirement. All of these components contribute to increasing the weight and inertia. Furthermore, the system adapts cable-driven transmissions to reduce backlash since backlash is a high frequency disturbance that cannot be compensated by  $DM^2$  beyond its control bandwidth [3]. These transmissions add to the complexity of the robot design and construction.

### C. New approach

Addressing these limitations, our investigation has led to the hybrid actuation concept and to the development of the Stanford Human Safety Robot,  $S2\rho$ , shown in Fig. 1. The key features embodied in  $S2\rho$  are the replacement of the heavy electrical actuators with pneumatic artificial muscles, the utilization of distributed compact pressure regulators, and the integration of newly designed robotic "bone" links. Due to the nature of pneumatic actuation, it generates high force for its size yet achieves low output impedance. A small on-joint electrical motor compensates for the low dynamics of the pneumatic muscle, allowing the hybrid actuation to achieve higher frequency bandwidth. The compactness of the newly designed pressure regulator enables control of the pneumatic muscle locally without increasing the flow resistance significantly. Since an air distribution system is incorporated into the bone, the regulators can be easily mounted on the bone without a significant increase in mass and assembly complexity. The major developments in our effort in human-friendly robot design are shown in Fig. 2.

## II. DESIGN CONCEPT

### A. Artificial Pneumatic Muscle

While an electrical motor generally provides high bandwidth, it has a force-to-weight ratio as small as 16:1 [7]. In order to generate high force, the system requires a high-power motor and/or a high gear reduction. This translates to a heavy and bulky system. In addition to weight and size, the effective inertia is also increased by the square of the gear reduction ratio. The higher force-to-weight ratio of a pneumatic actuator enables the system to be smaller and

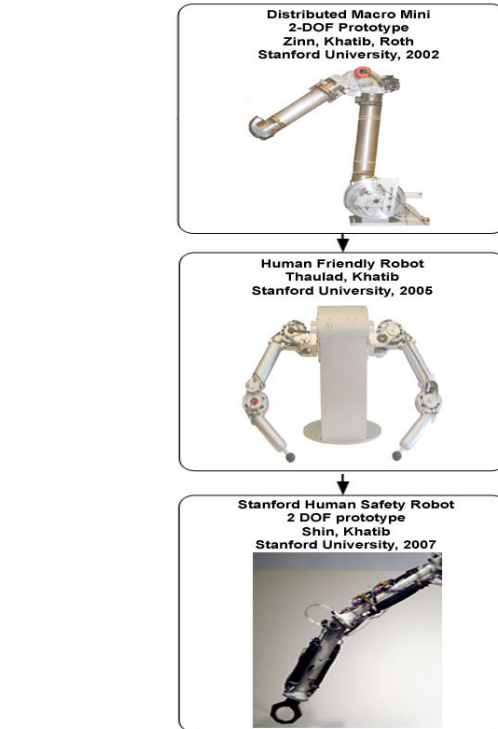

Fig. 2. Our recent studies in human-friendly robot design.

lighter with a lower gear ratio. In addition, the air compressibility inherently provides compliance without adding an elastic element. Since the output passive impedance at high frequency is decreased to the stiffness of the pneumatic muscle, the impact force during unexpected collisions can be reduced.

The pneumatic muscles employed in this work have a much higher force-to-weight ratio than a conventional pneumatic cylinder [13]. Furthermore, the pneumatic muscle is self-damping when contracting, and its flexible bladder material makes it inherently cushioned when it extends [7]. In addition to the flexible bladder material, the additional compliance from the air compressibility provides an increase in inertial decoupling of the macro pneumatic muscle from the load, which decreases high frequency impact loads.

### B. Compact Pressure Regulator

Because weight and size are essential aspects for safety in robot design, conventional/commercial pressure regulators, which are bulky and heavy, cannot be used in the arm. The pressure regulator must be located in the arm for improved performance because the distance between the pressure regulator and actuator must be as short as possible. In addition, unless the regulator is located in the arm, the tubes and fittings that would be necessary for the pressure regulator would increase the mass/inertia of the arm and the complexity of the design/assembly. A new pressure regulator, therefore, was designed for compactness while at the same time fulfilling the requirement of performance. The regulator consists of four parts: a pressure sensor, a solenoid valve, a

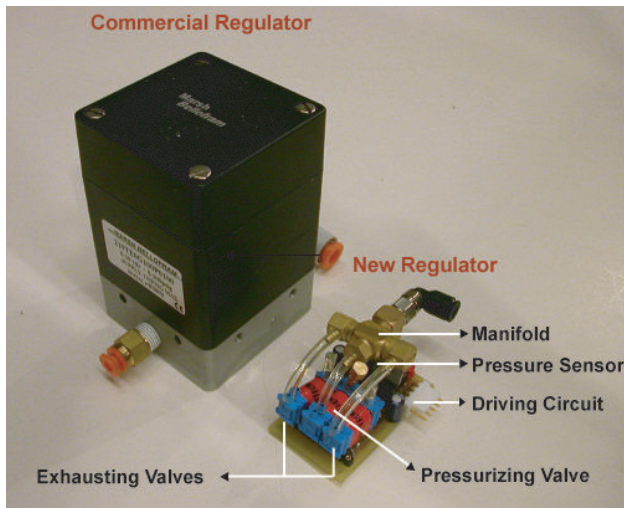

Fig. 3. The newly designed regulator is more compact than a commercial one. It consists of four parts: pressure sensor, solenoid valve, manifold and driving circuit.

manifold and a driving circuit as shown in Fig. 3.

Note that the flow rate of the valve depends not only on its orifice size, but also on the pressure difference across the valve. Since the pressure difference between the compressor and the pneumatic muscle is much higher than that between the pneumatic muscle and the atmosphere, the exhaust rate is usually lower than the pressurizing rate. This asymmetric flow rate between pressurizing and de-pressurizing might cause oscillation of the arm. Furthermore, the joint velocity is limited by the exhaust rate because the joint is driven antagonistically. To address this problem, an additional de-pressurizing valve is employed. In addition, the compactly designed manifold eliminates the need for complicated tubing and hence decreases the complexity of assembly as well as air flow resistance.

### C. Bone

1) *Integration*: A safe robotic arm must possess a low mass/inertia property without loss of performance. Many safe robot approaches, including the DM<sup>2</sup>, relocate the heavy actuator in the upper body to reduce the mass/inertia of the arm. This has the undesirable effect of the mass/inertia as well as increasing the complexity of the total system due to the additional transmission components. Conversely, the

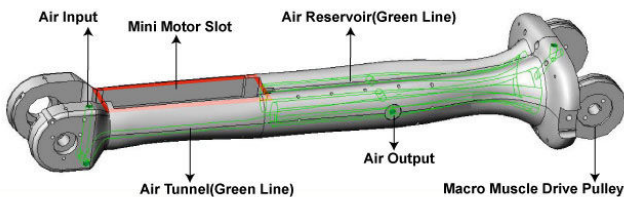

Fig. 4. Isometric view of the bone. The bone integrates the air distribution system, mini motor slot, and mechanical features such as macro muscle drive pulleys.

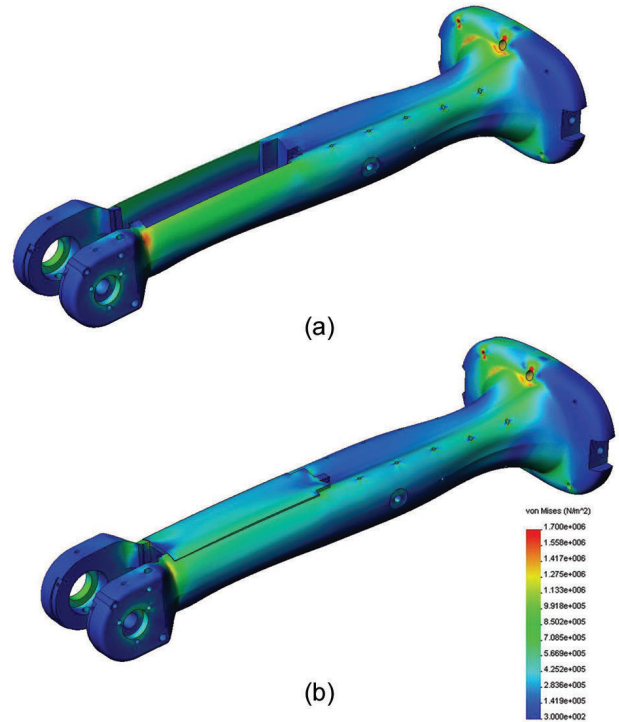

Fig. 5. Structural comparison of the bone in terms of von Mises stress. Simulation is conducted under the maximum force (200N) the pneumatic muscle generates. (a) Red spot shows the weakness on the neck of the bone without lid. (b) The lid provides structural strength while distributing the stress.

collocated actuator simplifies control of the system because the dynamics between the actuator and joint are less complex than they are for the remotely-located actuator. Furthermore, the integration of the actuator and its controller into each link increases the modularity of the robotic links. To take advantages of the collocated actuator, S2 $\rho$  employs a light yet powerful pneumatic muscle with a mini electrical motor on the joint. The limitation of this hybrid actuation is that it requires more components than a conventional arm that has an electrical motor alone. Additional components increase the mass/inertia and the complexity of design/assembly. The integration of the components is, therefore, essential to achieve safety as well as performance.

The bone contains an air distribution system, which includes the air reservoir, as shown in Fig. 4. The reservoir distributes air to each pressure regulator, and hence eliminates the need for additional complicated components that increase not only the weight but also the complexity of the design/assembly. The mini electrical actuator is embedded in the bone without extra components. This integration reduces the mass/inertia of the bone and maintains the center of mass at a geometrically central location along the bone. In addition, many mechanical components such as pneumatic muscle drive pulleys are integrated into the bone. This integration significantly decreases not only the mass/inertia but also the complexity of design/assembly.

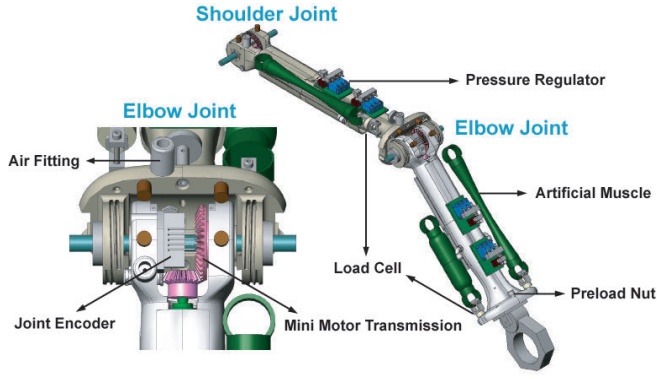

Fig. 6. Detailed view of the Stanford Human Safety Robot with a hybrid actuation approach.

2) *Structure*: A fundamental requirement for the safe robotic arm is for it to have low mass/inertia while maintaining the appropriate level of stiffness of the bone for high performance. This necessitates the selection of appropriate materials, as well as a sophisticated structural design and manufacturing method. Since the robotic link integrates the air distribution system and many features inside the bone, a three-dimensional manufacturing method such as Selective Laser Sintering (SLS) is chosen for feasibility. Among the available materials for SLS, glass-filled nylon possesses one of the best characteristics from the perspective of robotic structure. Regarding this structure, one of the most important concerns is the structural strength of the bone. The lid of the mini motor's slot (see Fig. 4) serves the essential function of strengthening the structure, as illustrated by the simulation in Fig. 5. In addition, the hollow structure with enclosed air distribution system increases the bending strength for a given amount of material.

3) *Optimal Linkage Length*: To generate the best dynamic performance in terms of the isotropic end-effector acceleration characteristic, the design parameters, especially for the ratio of the length of the two linkages, has been optimized [10]. To achieve large isotropic and uniform bounds on the end-effector, the ratio of 1.18 was chosen. The mean upper arm length to forearm length ratio of humans is 1.24 [11].

#### D. System Overview

S2 $\rho$  was built to provide a platform for implementing a hybrid actuation approach with artificial pneumatic muscles and electric motors. The platform has two degrees of freedom, and each joint is provided with two pneumatic muscles (Shadow Robot Company Ltd.) and one electric motor (Maxon RE26). The force of the pneumatic muscle is measured by a load cell (Omega LC202-100). Each muscle requires one bone-mounted pressure regulator, which consists of three solenoid valves (Parker X-Valve), a pressure sensor (Honeywell 40PC), and a driving circuit. The overall system is shown in Fig. 6. The range of motion and joint torque generated by a pneumatic muscle are tradeoffs since the maximum contraction of the pneumatic muscle is limited up

to 37% of its fully stretched length [7]. The requirements of range of motion and torque determine the choice of the pulley radius and initial pneumatic muscle length. The fully stretched length of the muscle is 210mm, with a maximum force of 250N. The joint characteristics of the pneumatic muscle are shown in Table I. The criteria for mini motor selection are high torque output, low reflected inertia, and compact size and transmission. The required torque is based on the assumption that the error of the macro pneumatic muscle is less than 20% of the maximum required torque for gravity compensation. The characteristics are shown in Table II. A bevel gear achieves compact right angle transmission, back drivability, and moderate stiffness for higher control bandwidth. Furthermore, its acetal plastic material provides low friction and assembly forgiveness. The link characteristics are shown in Table III.

	Pulley Radius	Max. Torque	Range
Shoulder	0.0305m	6.096N·m	54.156°
Elbow	0.0203m	4.064N·m	86.803°

TABLE I. CHARACTERISTICS OF MACRO MUSCLE ACTUATION

	Gear Ratio	Max. Torque	Reflected Inertia
Shoulder	28	0.963N·m	9.094 × 10 <sup>-4</sup> kg·m <sup>2</sup>
Elbow	10.8	0.372N·m	1.353 × 10 <sup>-4</sup> kg·m <sup>2</sup>

TABLE II. CHARACTERISTICS OF MINI MOTOR ACTUATION

	Weight	Length	Inertia(I <sub>zz</sub> )
Upper arm	1.024kg	0.340m	0.253kg·m <sup>2</sup>
Forearm	0.8472kg	0.289m	0.026kg·m <sup>2</sup>

TABLE III. LINK CHARACTERISTICS

### III. HYBRID ACTUATION CONTROLLER

The hybrid actuation control scheme adopts the Distributed Macro-Mini (DM<sup>2</sup>) control strategy [6]. The hybrid actuation controller separates commanded torques into the macro, i.e., pneumatic muscles, and the mini, i.e., electrical motor, on the basis of frequency content. The torque applied on the joint will then be the linear combination of the macro and mini torque contributions, as shown in Fig. 7.

The macro controller consists in a torque control based on the differential combination of pneumatic muscle force

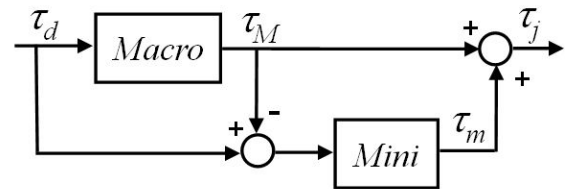

Fig. 7. Block diagram of Hybrid Actuation Control. The macro is an antagonistic pair of pneumatic muscles, the mini is an electrical motor.

feedback control. The force feedback, closing the control loop around the pneumatic muscle, thereby compensates for the pneumatic muscle force/displacement hysteresis phenomenon while also increasing the actuation bandwidth [12]. Given two forces, one from each muscle, the torque  $\tau_M$  applied to each joint is

$$\tau_M = R(F_1 - F_2) = R\Delta F \quad (1)$$

where  $F_1$  and  $F_2$  are the forces generated by the pneumatic muscles and  $R$  is the gear ratio of the joint. When the desired torque,  $\tau_d$ , is to be produced at the joint, the necessary force difference  $\Delta F_d$ , is symmetrically distributed between the two antagonistic muscles. Then a bang bang control adjusts the flow direction of a pressure regulator based on the load cell measurement. The bang bang control has been modified by introducing a dead band in order to avoid oscillations of the force during the steady state. For the mini controller, an open-loop torque controller compensates for low dynamics of the pneumatic muscle allowing the hybrid actuation to achieve higher frequency bandwidth.

#### IV. EXPERIMENTAL AND ANALYTICAL RESULTS

##### A. Performance Analysis

To analyze the performance of  $S2\rho$ , experiments of position tracking at increasing frequency were conducted. A position controller was implemented as an outer loop wrapped around the inner hybrid actuation controller. The desired torque of the hybrid actuation controller is given by

$$\tau_d = A(\ddot{q}_d - k_p(q - q_d) - k_v(\dot{q} - \dot{q}_d)) \quad (2)$$

where  $q_d$  and  $q$  are the desired and actual joint position,  $\dot{q}_d$  and  $\dot{q}$  are the desired and actual joint velocity, and  $A$  is the inertia matrix. Position tracking experiments were first carried out for the macro actuation. The same experiments were then carried out for the hybrid actuation.

In Fig. 8(a), the results of the pneumatic muscle actuation (Macro) and hybrid actuation (Macro-Mini) are plotted for the sinusoidal tracking frequency of 1 Hz. The results show that the hybrid actuation control is five times faster than the pneumatic muscle actuation alone. Moreover, the results in Fig. 8(b) demonstrate that the hybrid actuation is able to track the trajectory with a small error up to 3Hz, while the pneumatic muscle actuation alone shows significant phase and amplitude distortion.

##### B. Safety Analysis

For analyzing the safety due to impact at any point on the manipulator, Zinn et al. introduced Manipulator Safety Index (MSI) [6]. The MSI involves the effective mass/inertia, which can be graphically illustrated as a belted ellipsoid over the workspace plane [8]. Because the MSI mostly depends on the effective mass of the manipulator, the effective mass was simulated to demonstrate the safety of the proposed design in reducing the impact impulse. Fig. 9(a) displays the effective mass at the same shoulder and elbow configurations for the  $DM^2$  and  $S2\rho$ . It demonstrates that the effective

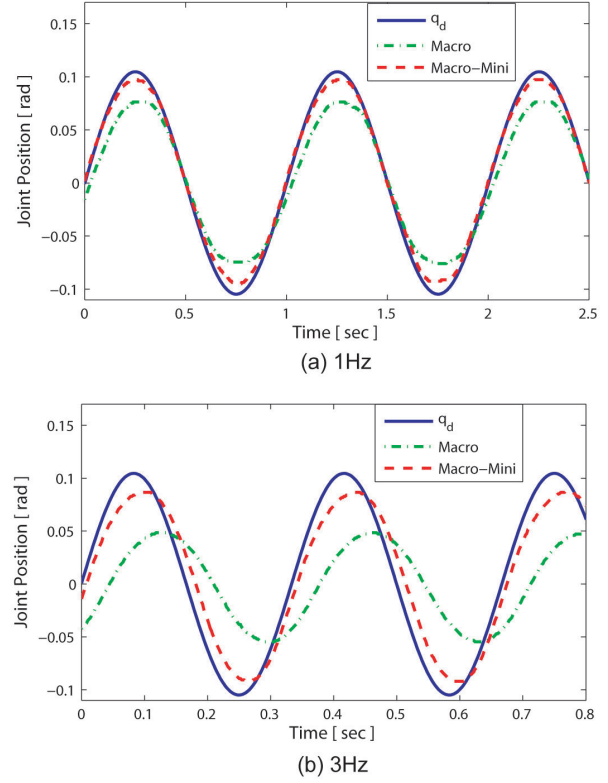

Fig. 8. Comparison of position tracking performance for pneumatic muscle actuation (Macro) and hybrid actuation (Macro-Mini) at 1 Hz and 3 Hz. (a) The result shows that the hybrid actuation is five times faster than the pneumatic muscle actuation alone. (b) The hybrid actuation is able to track the trajectory with a small error, while the pneumatic muscle actuation alone shows significant phase and amplitude distortion.

hybrid actuation approach reduces the effective mass by approximately a factor of two compared to the previous  $DM^2$ .  $S2\rho$  has a maximum effective mass of 1.4kg as compared to 3.5kg for  $DM^2$ . At the same configuration, a conventional robot such as PUMA560 has the far greater effective mass of 25kg [1].

The Manipulator Safety Index was also calculated, as shown in Fig. 9(b). It was calculated under a constant impact velocity of 3m/s, an average human head weight of 5.1kg, and the interface stiffness between head and arm of 37000N/m.  $S2\rho$  displays the best result of 2.8, while the MSI of a PUMA560 is 30 under the same conditions. The direction of maximum MSI value coincides with the direction of maximum end-effector effective mass. A frontal collision in this direction will yield the greatest likelihood of brain injury. When the MSI or equivalent  $HIC_{15}$  is less than 10, the probability of minor brain injury is zero [1]. The improved result compared to the previous  $DM^2$  approach shows that the safety of  $S2\rho$  is not compromised by an additional actuator, i.e., the pneumatic muscle. For better comparison, we provide the MSI of an average U.S. male civilian arm, which is sampled from surveys of U.S. populations [11].

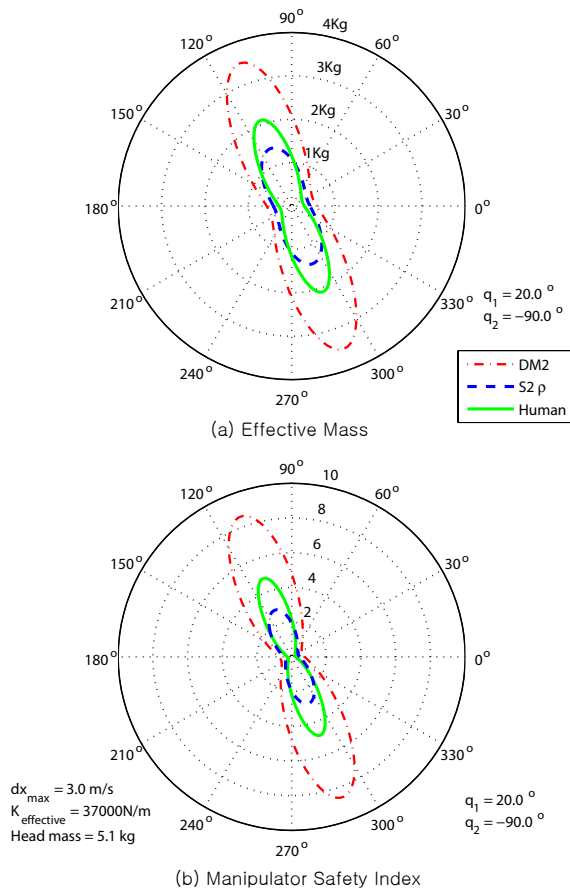

Fig. 9. (a) Effective mass of  $DM^2$ ,  $S2\rho$  and Human at  $q_1 = 20^\circ$  and  $q_2 = -90^\circ$ .  $S2\rho$  has a maximum effective mass of 1.4kg as compared to 3.5kg for  $DM^2$  and 2.2kg for Human, while conventional PUMA560 has an effective mass of 25kg. (b) The Manipulator Safety Index (MSI) of  $DM^2$ ,  $S2\rho$  and Human at the same configuration. When the MSI or equivalent  $HIC_{15}$  is less than 10, the probability of minor brain injury is zero. [1]

## V. CONCLUSION AND DISCUSSION

The concept of hybrid actuation is presented with the development of a human-friendly robotic arm, referred to as  $S2\rho$ . The artificial pneumatic muscle enables the prototype arm to be light, compact and compliant due to its high force-to-weight ratio and air compressibility. The distributed compact pressure regulators decrease not only air flow resistance, but also the complexity of robot design and construction. The human-bone-inspired robotic link drastically reduces the mass property as well as the complexity of design and manufacturing. The experimental results show significant performance improvement with the hybrid actuation over the arm with pneumatic actuation alone. The simulations using the MSI validate the arm safety characteristic, which is comparable to those of a human arm. However, the following issues need to be addressed:

### A. Limited range of motion (Pneumatic muscle)

A wide range of motion and high joint torque are a tradeoff due to the limited contraction ratio of pneumatic muscles. To

obtain sufficient torque with a wide range of motion, multiple muscles in parallel with a small pulley will be exploited.

### B. Low flow rate and slow response (Pressure regulator)

For future designs, multiple muscles will be connected in parallel in order to increase the force while maintaining or increasing the range of motion. Therefore, a pressure regulator with a higher flow rate and a faster response time is necessary as well as an enhanced controller.

### C. More compact and lighter design (Bone)

For higher strength-to-weight/volume, aesthetics, and easier integration/modularization, a new bone will be designed and manufactured with Shape Deposition Manufacturing [9].

## VI. ACKNOWLEDGMENTS

The authors gratefully acknowledge the contribution of Jaeheung Park and Francois Conti at Artificial Intelligence Laboratory, Stanford University, and Prof. M.C. Carrozza at Scuola Superiore Sant'Anna of Pisa.

## REFERENCES

- [1] P. Thaulad, "Human friendly robot control system design and experimental validation", Degree of Engineer Thesis, Stanford University, Stanford, CA, 2005.
- [2] Gill Pratt and Matt Williamson, "Series elastic actuators", In Proc. of IEEE/RSJ International Conference on Intelligent Robots and Systems, volume 1, pp. 399-406, 1995.
- [3] J.B. Morrel, "Parallel Coupled Micro-Macro Actuators", PhD thesis, Massachusetts Institute of Technology, Cambridge, MA, 1996.
- [4] A. Bicchi and G. Tonietti, "Fast and "soft-arm" tactics, In IEEE Robotics and Automation Magazine, volume 11, pp. 22-33., IEEE, 2004.
- [5] Michael Zinn. A New Actuation Approach for Human Friendly Robotic Manipulation. PhD thesis, Stanford University, Stanford, CA, 2005.
- [6] M. Zinn, O. Khatib, B. Roth, and J.K. Salisbury. Towards a human-centered intrinsically-safe robotic manipulator. In Proc. of IARP/IEEE-RAS Joint Workshop, Toulouse, France, 2002.
- [7] Website of Shadow Robot Company Ltd., United Kingdom, "Http://www.shadowrobots.com"
- [8] O. Khatib, "Inertial properties in robotic manipulation: An object-level framework," Int. J. Robotics Res., vol. 14, no. 1, pp.19-36, 1995
- [9] Weiss, L.E., Merz, R, Prinz, F.B., Neplotnik, G, Padmanabhan, P, Schultz, L, and Ramaswami, K., "Shape deposition manufacturing of heterogeneous structures," Journal Of Manufacturing Systems, v.16, no.4, pp.239-248., 1997
- [10] O. Khatib, J. Burdick, "Dynamic optimization in manipulator design: The operational space formulation", The International Journal of Robotics and Automation, 2(20):90-98, 1987
- [11] D. Chaffin, G. Andersson, B. Martin, "Occupational Biomechanics", Fourth Edition, Wiley, pp.47-49, 2006
- [12] I. Sardellitti, J. Park, D. Shin, O. Khatib, "Air Muscle Controller Design in the Distributed Macro-Mini( $DM^2$ ) Actuation Approach", In Proc. of the IEEE/RSJ International Conf. on Intelligent Robots and Systems, 2007
- [13] B.Tondu, P. Lopez, "The McKibben muscle and its use in actuating robot-arms showing similarities with human arm behaviour", The Industrial Robot. Bedford: Vol. 24, Iss. 6; pg. 432, 1997