

New Computer Protocol with Subsensory Stimulation and Visual/Auditory Biofeedback for Balance Assessment in Amputees

Ming-Yih Lee

Chang Gung University Graduate Institute of Medical Mechatronics /Department of Mechanical Engineering,
Tao Yuan, Taiwan

Email: leemiy@mail.cgu.edu.tw

Kok-Soon Soon

Chang Gung University Graduate Institute of Mechanical Engineering /Department of Mechanical Engineering,
Tao Yuan, Taiwan

Email: d9422002@stmail.cgu.edu.tw

Abstract—In this study, we hypothesized that the static standing weight bearing steadiness and dynamic walking weight shifting stability could be improved by providing neuromuscular facilitation using subsensory stimulation and visual–auditory biofeedback in amputee respectively. To test this hypothesis, a computer protocol with sensory feedback neuromuscular facilitation system was developed and used for clinical assessment. Seven unilateral transtibial amputees who consecutively worn prosthetics over two years were recruited. Experimental results show a reduction in all of the postural sway related indices and increase in single-leg holding time index during static quiet standing by applying subsensory stimulation. With visual–auditory biofeedback for providing clue for heel contact and toe push-off condition during dynamic ambulation, an improvement in all four dynamic walking weight shifting stability indices in amputees was verified. This study provided evidence that sensory feedback neuromuscular stimulation may put amputees at better balance capability.

Index Terms—static standing weight bearing, steadiness, dynamic walking weight shifting, stability

I. INTRODUCTION

In patients after amputation, the decrease in body weight accompanied by an alteration in the position of the centre of mass over the base of support will be inadequate in weight acceptance, single limb support, and limb advancement, which will prevent them from attaining adequate balance control and a normal walking pattern [1–3]. Experimental evidences show that amputees have a decreased stance time on the prosthetic side, shortened stride length on the sound limb, or lateral trunk bending over the amputated side. A well-planned postoperative prosthetic training program can improve balance control and walking pattern for the amputees [3–7].

Somatosensory feedback is an important component of the human balance control system. Recent studies proved that tactile stimulation in the foot sole contributes to the

coding and the spatial representation of body posture [8]. Several clinical studies show that the subsensory noise stimulation (electrical or mechanical), so-called stochastic resonance stimulation (SRS), can enhance the sensitivity of the human somatosensory system [6], [9]. To date, the role of sensory feedback in the lower-limb amputees have received very limited attention. In this paper, we examined the effects of subsensory input to the somatosensory system on postural control in amputees. We hypothesized that the static standing weight bearing steadiness and dynamic walking weight shifting stability could be improved by applying foot pressure sensory feedback and neuromuscular stimulation, respectively. To test this hypothesis, a foot pressure activated system, integrated with subsensory electrical stimulation and visual–auditory biofeedback mechanism, was developed and used for clinical study. To investigate the effect of the subsensory electrical stimulation and visual–auditory biofeedback on posture control, a series of tests on amputee subjects were conducted in this pilot study.

II. METHODS

A. System Development

The conceptual design of the proposed sensory feedback neuromuscular facilitation system for enhancing static standing weight bearing steadiness and dynamic walking weight shifting stability for amputees was illustrated in Fig.1. The proposed system consists of a custom-designed artificial leg with foot pressure measurement sensors attached, a microcomputer-based control unit, subsensory electrical stimulation unit, and visual–auditory biofeedback unit. Foot pressure sensors were attached to the bottom of the artificial leg to monitor the subject's gait sequence during walking test. Microcomputer-based control unit was designed to receive the foot pressure signal and to generate the

subsensory electrical stimulation signal based on the built-in control rule. The visual-auditory biofeedback units were integrated to provide clues for heel contact and toe push-off condition during dynamic treadmill ambulation. The detailed description of the proposed system components is presented as follows.

1) Artificial Leg with Foot Pressure Sensors: In this study, two force sensing resistors (FSRs) (18.3mm×12.7mm×0.46mm; Interlink Electronics, Camarillo, CA) were used to detect the heel contact and toe push-off conditions of artificial leg as shown in Fig.2. The foot-pressure signal is sent to the main control unit to generate the visual-auditory biofeedback signal to the subject, once the amount of ground reaction forces exceed certain specified threshold value. In another words, the visual-auditory biofeedback unit will be triggered according to the amputee's gait pattern for providing sensory compensation.

2) Microcomputer-based Control Unit: The microcomputer-based control unit is comprised of 8051 single-chip microcomputer (AT89C52, Atmel Corporation, USA), signal amplifier, A/D converter (model AD7828LP, Analog Devices Ltd), RAM, 9-V power supply, and electrodes. The functions of the microcomputer-based control unit included receiving foot-pressure signal from foot-pressure measurement unit, generating the stochastic resonance stimulation signal, facilitating functional electrical stimulation signals, uploading foot-pressure information to visual-auditory stimulation unit, etc. The transmission rate between the microcomputer-based control unit and the PC is 9600 bits/s or 1200 bytes/s (i.e., 1 byte = 8 bits). The transmission time is 833.33 μ s (i.e., 1/1200). The A/D converter has eight channels (8 bits), the time consumed for an analog signal for each channel is 100 μ s. Therefore, the time delay of the closed-loop feedback systems from the detection of the foot pressure to the triggering onset of the visual-auditory output is 8ms [(833.33 μ s + 100 μ s) × 8 = 7466.64 μ s = 8ms].

3) Visual-auditory Feedback Unit: The auditory biofeedback functioned as an alarm and was feedback to the subject through two loudspeakers connected to the PC. The ground reaction force of the artificial leg can be detected by force sensors placed on the heel and toe region below the artificial leg. The output range of the FSR force sensor (i.e., 0–10 kg) was categorized into three subranges corresponding to three beeping sound volume levels (i.e., low, medium, and high level) for auditory biofeedback. The volumes of the beeping sound depend on the load of subject. Therefore, the proposed visual-auditory biofeedback mechanism provides hint for the subject to modulate his/her gait pattern and weight shift during ambulation.

The visual feedback, which was designed through a control screen placed in front of the subject whose plantar foot-pressure distribution can be easily visualized. On the right part of the control screen is the real-time display of the plantar foot-pressure distribution. The heel strike and toe off conditions were detected by the two sensors below the heel and metatarsal regions. The detected pressures

were shown with colors in the corresponding region of the foot-shape picture. A range of colors, from white to yellow to red indicated the intensity of the pressure exerted under each location. Closeness to red color indicated higher intensity of the exerted force. The visual biofeedback provides hint for the subject to control and modulate his/her gait pattern and weight shift.

4) Subsensory Stimulation Unit: The subsensory stimulation unit is an electrical stimulation device with controlled electrical input according to the sensation threshold of each subject. The flow chart of control signal of subsensory stimulation unit is show in Fig.3. The stimulation amplitude was set well below the cutaneous sensation threshold of each subject, as confirmed by a threshold measurement prior to testing. As a result, the subjects were blinded to the treatment condition. At the outset of the testing session, each subject was asked to determine his or her pain threshold for electric current on the quadriceps muscle of the stance leg surface while static quiet standing. A potentiometer was used to adjust the amplitude of the stimulation signal for each trial. The subject was asked to adjust the potentiometer to determine the threshold at which he or she could no longer feel the stimulation. The low-level signal used here was a triangular waveform generated by a function generator with 0–60 mA in amplitude and 500 ms in period. The subsensory triangular signals were applied through surface electrodes on quadriceps of the subject's lower extremity. The electrodes were rectangular (4 cm × 4.8 cm) self-adhesive gel pads, aligned with the longitudinal axis along the joint axis line formed by the femoral and tibial condyle. The subsensory stimulation signal was applied for the entire duration of the stimulation trial. The stimulation level for the experiments was set to 90% of this threshold level for each leg. Thus, the applied low-level electrical signals were subsensory, and subjects could not distinguish between experiment group with electrical signal and control trials. A built-in stimulation current limiter is also designed to stabilize the stimulation current signal during the experiment. To monitor the performance of the current limiter, a digital readout can be shown on the controller's screen during the stimulation period. The "+" or "-" keys on the keyboard are designed for manual setting of the controlled threshold.

B. Patient Selection

Seven unilateral transtibial amputee subjects (five males and two females, age 24–60 years, mean age 38.86 ± 14.08 years, weight 59.86 ± 6.91 kg), who wore prosthetic over two years consecutively, volunteered to participate in this paper. Demographic data of tested subjects is summarized in Table 1. Two subjects unable to tolerate dynamic walking weight shifting stability test were excluded from the study. Potential subjects were randomly selected and extracted from the database of the Department of Physical Medicine and Rehabilitation, Rehabilitation Hospital, Chung Shan Medical University, Taichung, Taiwan. A self-reported medical history screened potential participants for orthopedic or

neurological conditions such as Parkinson's disease, diabetes, peripheral neuropathy, stroke, disabling arthritis, uncorrected visual problems, dizziness or vertigo, use of assistive walking devices, joint injury, and joint implants. Subjects who reported these conditions were excluded from the study. The study was approved by the ethics committee of cooperation hospital. All subjects signed an informed consent before entering the study.

C. Experimental Protocol

1) *Static Standing Weight Bearing Steadiness Tests:* Subjects were asked to maintain balance without subsensory stimulation (control group) and with subsensory stimulation (experimental group) on the sound side leg for as long as they could, with arms across their chest and with a steady forward focus. Subjects were allowed to stretch their arms out to the side if needed for balance. Subjects maintained a small amount of flexion in their stance knee joint during the balance task and were performed with the subject in single-leg quiet standing position. If the subject touched the floor with the swing leg, the trial is considered to be over. Subjects performed two to three practice trials before data were recorded by the Zebris force measurement system. The static standing weight bearing steadiness test was performed six times, without subsensory stimulation applied in random order during three of the six trials. Sit-down rest for 15 min was provided after every trial. During the three stimulation trials, electrical input was applied through surface electrodes on the lateral aspects of the subject's quadriceps muscle in the sound side leg. The electrical stimulation signal was applied for the entire duration of the stimulation trial. After the subjects completed each static standing weight bearing steadiness test, they were instructed to stand as motionless as possible, while maintaining their hands beside their iliac crests with their head positioned straight ahead. To provide a safety measure for preventing subject's falling during the experiments, a safety harness was used for all subjects. The harness was suspended from the ceiling and was adjusted so that it was not supporting the subject's weight but would catch the subject if they completely lost balance.

2) *Dynamic Walking Weight Shifting Stability Tests:* The second experiment for evaluating the effects of visual-auditory biofeedback to the weight shifting stability during treadmill ambulation for lower extremity amputee subjects was performed (shown in Fig. 4). The control group's subjects were provided no visual-auditory biofeedback. On the contrary, those who were provided visual-auditory biofeedback were considered as the experimental group. A commercial available treadmill (model AG-7600, Aerogym Trading Company, Taichung, Taiwan, R.O.C.) was used as a dynamic walking weight shifting stability test platform in this study. Subjects were asked to wear their prosthetic leg with two FSRs below the artificial leg. In order to provide visual-auditory biofeedback synchronized with the subject's gait cycle, the Zebris instrumented insoles were used. Subjects were asked to walk at their natural, freely chosen speed (mean speed 4.5 km/h) and cadence on a commercially available

motorized treadmill. The test subjects walked on the treadmill for 20 min in each test session. Each test session included 5 min to warm up, 10 min of training period, and 5 min to cool down. Speed was increased each minute, as far as they could tolerate. In addition, no physical assistance was provided, and heart rate of the subject was monitored.

In this study, the posture control performance was characterized using a Zebris forcemeasurement system (model CMS-HS, Zebris Medizintechnik GmbH., Isny im Allg'au, Germany) for measuring the body center of mass (COM) sway pattern of the subjects. A passive marker was placed on second sacral (S2) for representing the COM of the subject. This passive marker consists of a small ultrasonic microphone, and was connected to the control unit of the Zebris system. Three sequentially active ultrasonic transmitters in the measuring unit of the Zebris system send continuous pulses during operation. The distance between the transmitter and the passive marker was determined through the running time of the pulse. By triangulation, the absolute 3-D coordinates of the COM of the subject can be determined. To synchronize the gait phases, the Zebris instrumented insoles were used. Each of the insoles contained four force sensors and a total of 100 capacitive-force-sensing elements in the heel, midfoot, left toe, and right toe area. The analog output signals of force sensors were directly proportional to the forces supplied to the measurement points. The sampling rate for the Zebris instrumented insole for the measurement data collected was 50 Hz. In this paper, the duration and body (COM) sway pattern were recorded for balance evaluation during static standing weight bearing steadiness tests. For the dynamic walking weight shifting stability tests, the force distributions of the left and right instrumented insoles were recorded for dynamic postural control assessment.

III. OUTCOME MEASURES

A. Static Standing Weight Bearing Steadiness Indices

Four different static standing weight bearing steadiness indices were defined and used for assessment. One index is time-related measure and the other three indices were body-sway-related measures. The detailed definition of each balance index was elaborated as follows.

- 1) *Holding Time Index (HTI):* Total duration in which the subject maintains balance on a single leg.
- 2) *Sway Length Index (SLI):* Total distance between consecutive points on the COM trajectory over a constant time interval.
- 3) *Maximum Sway Distance Index (MSDI):* The longest distance from the origin point to each sampling point on the COM trajectory.
- 4) *Average Sway Distance Index (ASDI):* The summation of sway length between origin points to each sampling point on the COM trajectory divided by the total number of samplings.

The expectation of the above mentioned measurements when applying subsensory stimulation is: increase in HTI

and decrease in the other three indices (i.e., SLI, MSDI, and ASDI).

B. Dynamic Walking Weight Shifting Stability Indices

In addition, four different dynamic walking weight shifting stability indices were defined and used for assessment. All the four indices are temporal (timing) domain measures. The detailed definition of each balance index was elaborated as follows.

- 1) *Double Support Time Symmetry Index (DSTSI)*: The double support time symmetry index (DSTSI) measures the symmetry time elapsed for the gait cycle when both lower extremities are in contact with the support surface. This index is defined as the double support time of sound side divided by the double support time of the affected side. This method for scoring symmetry was selected based on the observation that the double support time of the sound side was less than that of the affected side for every subject. A score of 100 would indicate symmetry while a score under 100 would indicate a shorter double support time of the sound side than the affected side.
- 2) *Constant Time Step Number Index (CTSNI)*: The cadence is the number of steps taken in a given time, the units is steps per minute. There are two steps in a single gait cycles are counted, the cadence is a measure of half-cycles. Measurement in steps per minute does not conform to the System International (SI).
- 3) *Single Support Time Symmetry Index (SSTSI)*: The single support time symmetry index (SSTSI) measures the symmetry period of the gait cycle when single lower extremity is in contact with the supporting surface. This index is defined as the single support time of sound side divided by the single support time of the affected side. This method for scoring symmetry was selected based on the observation that the single support time of the sound side was less than that of the affected side for every subject. A score of 100 would indicate symmetry while a score under 100 would indicate a shorter single support time of the sound side than the affected side.
- 4) *Gait Phase Time Ratio Index (GPTRI)*: The gait phase time ratio index (GPTRI) measures the symmetry ratio between time fraction of stance phase and swing phase over a single gait cycle. In a normal gait cycle, the time elapsed of the stance phase is about 60% of the complete step and the swing phase is about 40% of the complete step [10]. Therefore, the ratio of the time elapsed between stance phase and swing phase can normally be assumed as 1.5 (i.e., $0.6/0.4$). The improvement ratio of GPTRI is measure by calculating the change in ratio between experiment group and control group divided by the total gait phase time changed.

The above mentioned performance indices under visual–auditory biofeedback test conditions were

expected to be increase in three indices (DSTSI, CTSNI, and SSTSI) and approach to 1.5 in the GPTRI.

IV. RESULTS

A. Static Standing Weight Bearing Steadiness Tests

From the results of the static standing weight bearing tests, the single leg stand holding time of all five subjects increased with subsensory electrical stimulation, indicating an overall improvement in balance performance in the stimulation condition. In addition, the SLI, MSDI, and the ASDI were found to decrease for all five subjects. The improvement ratio of four balance performance indices across subjects resulted in an increase of 125.5% in HTI, 12.95% in SLI, 31.03% in MSDI, and 61.41% in ASDI, respectively, as shown in Table II. For each of these measures, all five subjects showed improvement with electrical stimulation.

B. Dynamic Walking Weight Shifting Stability Tests

From the results of the dynamic walking weight shifting stability tests, the affected side DSTSI and SSTSI were found to decrease for all five subjects. In addition, the CTSNI and sound side SSTSI showed an increase. The improvement ratio of four gait performance indices across subjects resulted in a 5.92% in DSTSI, 7.88% in CTSNI, 3.04% in SSTSI, and 55.84% in GPTRI. For each of these measures, all the five subjects showed improvement with visual–auditory biofeedback (Table III).

V. DISCUSSIONS

A. Static Standing Weight Bearing Steadiness

This study demonstrated that imperceptible low-level electrical stimulation with triangular waveform, when applied to the quadriceps, could enhance the static standing weight bearing steadiness performance of lower extremity amputee patients. The fact that balance performance was improved when subsensory electrical stimulation was applied demonstrates an overall reduction in postural sway and increase in single-leg support time, and suggests that balance perturbations in any task might be more easily overcome with the application of low-level electrical stimulation signals. From Table II, the improvement ratio of static balance performance indices noted in this study were in the range of 12.95%–125.5%.

A promising rehabilitation strategy using low-level noise stimulation (either electrical or mechanical) has recently been shown to improve the sensitivity of the human somatosensory system. In addition, use of sensory feedback has proven an effective supplement to conventional hands-on therapy in the rehabilitation of balance disorder [11]. In this study, we extended the effect of low-level electrical inputs, instead of noise, applied to the quadriceps muscle on the amputee subjects. The experimental evidence of this study suggests that subsensory electrical stimulation even with nonstochastic waveform (such as triangular waveform) is also effective

in enhancing the function of the human sensor-motor system. The comparison of subsensory electrical stimulation with different waveforms (i.e., noise, triangular, etc.) on the amputee's balance performance will be followed.

The subsensory electrical stimulation used in this study is likely to be effective in enhancing the function of the human sensor-motor system because of the electrical nature of information transfer in sensory neurons. Low-level electrical signals can cause small changes in receptor transmembrane potentials. This depolarization in the local membrane potential brings the neuron closer to threshold, thus, making it more likely to fire an action potential in the presence of a weak signal. The electrical depolarization, when combined with graded potentials from mechanical stimuli, could provide a mechanism by which normally subsensory mechanical stimuli become detectable in the presence of low-level electrical signals.

According to clinical studies [1-2], [12], the low-level electrical stimulation is likely to be effective in enhancing the function of the human sensorimotor system because of the electrical nature of information transfer in sensory neurons. This study demonstrated that even the stimulation waveform is triangular. The experimental results from the balance indices of the five tested subjects tend to be an improvement phenomenon. In the future, the comparison of subsensory electrical stimulation with different waveforms (i.e., noise, triangular, etc.) on the amputee's balance performance will be followed.

B. Dynamic Walking Weight Shifting Stability

This study also demonstrated that the visual-auditory proprioceptive biofeedback was more effective in improving dynamic postural control capabilities for amputee patients. The results of this study showed an improvement in the affected side DSTSI for all five subjects. This experimental evidence indicates that the visual-auditory biofeedback may guide the subject toward the right way of dynamic ambulation.

The increasing sound side SSTS for all five subjects is also the proof of enhancing the gait function. In the condition without visual-auditory biofeedback, experimental results showed longer double support time in the affected side and shorter double support time in the sound side. These results implied that visual-auditory or proprioceptive biofeedback is an effective way to achieve dynamic balance in gait asymmetry in lower extremity amputee patients.

It is often more convenient to study gait while the subject walks on a treadmill rather than over the ground, since subjects can conveniently be connected to wires of the measurement devices. However, there are subtle differences between treadmill and over ground gait, particularly with regard to joint angles. Besides, the subject's awareness of the limited length of the treadmill belt may cause increasing of cadences (shortening of the stride length). The most important differences are probably due to changes in the speed of the treadmill belt as the subject's feet decelerate it at initial contact and accelerate it at push off, effectively storing energy in the treadmill motor. The effect is minimized by using a large

treadmill with a powerful motor [13]. Previous study has shown that amputee gait is asymmetrical as compared to the normal gait [14]. In addition, experimental results indicated that the asymmetry occurred in the stance phase (longer for the intact leg) and the swing phase (shorter for the intact leg). The majority of the patients took a longer step with the prosthetic leg. Some studies indicated that the amputated person could only vary gait speed with the healthy leg, because of the inability of the artificial knee-joint to adjust actively. In this study, it is worth noting that increase in cadence (CTSNI) and symmetry in gait (GPTRI) with visual-auditory proprioceptive biofeedback can be achieved.

In addition, the proposed system was accepted by all amputees in this study. All the tested subjects evaluated it as comfortable and helpful in encouraging ambulatory training. Especially, auditory feedback was found useful by both amputees and therapists: amputees to monitor the adequacy of their gait pattern, therapists to monitor patient progress and achievements during therapy sessions. However, visual biofeedback seemed to be of less value. Most of the tested subjects did not make good use of the information presented on the monitor. The reasons for the poor use of the visual feedback may be mainly due to the interference with the auditory biofeedback. Most subjects were easily adopting the auditory biofeedback than the visual biofeedback.

Although the outcome of this study suggested that both subsensory electrical stimulation and visual-auditory biofeedback were effective on the improvement of either static balance or dynamic gait performance, respectively, the combined effect of these two proprioceptive rehabilitative strategies on balance performance remains to be followed up. Further work involving a larger sample of subjects is needed to test our hypothesis. In addition, there is also a need for more extensive clinical assessment and classification of amputees to determine the extent to which different amputee populations can benefit from the proposed strategies.

This pilot study constitutes the first steps toward assessing the clinical significance of using subsensory electrical stimulation and visual-auditory biofeedback to improve static standing weight bearing steadiness and dynamic walking weight shifting stability for amputees. This work indicated that the proposed sensory feedback neuromuscular facilitation system could improve performance during quiet standing and ambulation. The subsensory stimulation and visual-auditory biofeedback techniques may prove useful in overcoming sensory loss for unilateral transtibial amputees.

VI. CONCLUSION

The loss of motor capability and biofeedback from the lower limb affects the amputee's ability to establish and maintain his or her static standing weight bearing steadiness and dynamic walking weight shifting stability. For amputees, this deficit is demonstrated in characteristic COM sway pattern and gait deviations. This pilot study suggests that subsensory electrical stimulation and visual-auditory biofeedback strategies

may be effective in improving static standing weight bearing steadiness and dynamic walking weight shifting stability in lower extremity amputees. A new computer protocol with subsensory stimulation and visual/auditory biofeedback for balance assessment in amputees was developed and used for this study. The experimental results suggested that the proposed sensory feedback neuromuscular facilitation system may be effective in achieving static standing weight bearing steadiness and dynamic walking weight shifting stability for amputees. A full exploration of the benefits of biofeedback for lower-limb amputees is necessary to definitively establish the need to incorporate this technique into the treatment of amputees. In the future, the proposed system may be redesigned as a wearable prosthetic, which may potentially reduce the frequency and severity of falls for lower extremity amputee patients. Further research will continue to study the effects of the magnitude and different forms of stimulation on the performance indices.

REFERENCES

- [1] J. D. Harry, J. B. Niemi, A. A. Priplata, and J. J. Collins, "Balancing act," *IEEE Spectrum*, vol. 42, no. 4, pp. 36–41, Apr. 2005.
- [2] J. J. Collins, A. A. Priplata, D. C. Gravelle, J. B. Niemi, J. Harry, and L. A. Lipsitz, "Noise-enhanced human sensorimotor function," *IEEE Eng. Med. Biol. Mag.*, vol. 22, no. 2, pp. 76–83, Mar./Apr. 2003.
- [3] R. Roll, A. Kavounoudias, and J. P. Roll, "Cutaneous afferents from human plantar sole contribute to body posture awareness," *Neuroreport*, vol. 13, pp. 1957–1961, Oct. 2002.
- [4] L. Mouchnino, M. L. Mille, M. Cincera, A. Bardot, A. Delarque, A. Pedotti, and J. Massion, "Postural reorganization of weight-shifting in below knee amputees during leg raising," *Exp. Brain Res.*, vol. 121, pp. 205–214, Jun. 1998.
- [5] R. B. Huitema, A. L. Hof, and K. Postema, "Ultrasonic motion analysis system measurement of temporal and spatial gait parameters," *J Biomech*, vol. 35, pp. 837–842, Jun. 2002.
- [6] N. T. Dhruv, J. B. Niemi, and J. D. Harry, "Enhancing tactile sensation in older adults with electrical noise stimulation," *Neuroreport*, vol. 13, pp. 597–600, Apr. 2002.
- [7] G. F. Fernie, "Biomechanics of gait and prosthetic alignment," in *Amputation Surgery and Rehabilitation, the Toronto Experience*, J. P. Kostuik, Ed. New York: Churchill Livingstone, 1981, pp. 259–265.
- [8] L. Mouchnino, M. L. Mille, M. Cincera, A. Bardot, A. Delarque, A. Pedotti, and J. Massion, "Postural reorganization of weight-shifting in below knee amputees during leg raising," *Exp. Brain Res.*, vol. 121, pp. 205–214, Jun. 1998.
- [9] G. T. Wannstedt, R. M. Herman, "Use of augmented sensory feedback to achieve symmetrical standing," *Phys Ther* 1978, 58:5, pp. 553–559.
- [10] W. Liu, L. A. Lipsitz, M. Montero-Odasso, and J. Bean, "Noise-enhanced vibrotactile sensitivity in older adults, patients with stroke, and patients with diabetic neuropathy," *Arch. Phys. Med. Rehabil.*, vol. 83, pp. 171–176, Feb. 2002.
- [11] G. T. Wannstedt, R. M. Herman, "Use of augmented sensory feedback to achieve symmetrical standing," *Phys Ther* 1978, 58:5, pp. 553–559.
- [12] N. T. Dhruv, J. B. Niemi, J. D. Harry, L. A. Lipsitz, and J. J. Collins, "Enhancing tactile sensation in older adults with electrical noise stimulation," *Neuroreport*, vol. 13, pp. 597–600, Apr. 2002.
- [13] H. H. C. M. Savelberg, M. A. T. M. Vorstenbosch, and E. H. Kamman et al, "Intra-stride belt-speed variation affects treadmill locomotion," *Gait and Posture* 1998, 7: 26–34.
- [14] V. T. Inman, H. J. Ralston, and F. Todd, *Human Walking*, J. C. Lieberman, Ed., Baltimore, MD: Williams & Wilkins, 1981, pp. 41–55.

Ming-Yih Lee (M'96) received the Ph.D. degree in mechanical engineering from the University of Minnesota, Minneapolis, in 1991. From 1984 to 1992, he was a Robotic Engineering Manager with CIMCORP, Inc., St. Paul, MN. He is currently a Professor and the Chairman of the Graduate Institute of Medical Mechatronics at Chang Gung University, Tao Yuan, Taiwan, R.O.C. Since 2001, he has been the Director of the National Medical Mechatronics Educational Resource Center (MMERC) sponsored by the Ministry of Education (MOE) in Taiwan. He has authored or coauthored more than 350 papers published in several scientific journals and conference proceedings. He is an Associate Editor of the ASME Journal of Medical Device.

Prof. Lee is the Chairman of the IEEE Robotics and Automation Society (RAS) Taipei Chapter and the Technical Committee (TC) on Medical Mechatronics of the IEEE Systems, Man, and Cybernetics Society. He received the Distinguished Engineering Professor Award from Chinese Mechanical Engineering Association in 1998, the Golden Brain Award in the National Invention Competition in Taiwan consecutively from 1997 to 1999, and Best Paper Awards from various professional societies. He also represented Taiwan to win three gold medals at the Nuremberg International Invention Exhibition from 1998 to 2000.

Kok Soon Soon received the M.S. degree in medical mechatronics engineering in 2005 from Chang Gung University, TaoYuan, Taiwan, R.O.C., where he is currently working toward the Ph.D. degree in mechanical engineering.

His research interests include clinical electrical devices design and rehabilitation neuroscience.

TABLE I. DEMOGRAPHIC DATA OF PARTICIPANTS.

	<i>Subject I</i>	<i>Subject II</i>	<i>Subject III</i>	<i>Subject IV</i>	<i>Subject V</i>	<i>Subject VI</i>	<i>Subject VII</i>	<i>Average</i>
Prosthesis worn (yrs)	12	18	10	1.5	2	4	12	8.5 ± 6.12
Gender	Male	Male	Female	Male	Male	Female	Male	—
Age (yrs)	24	42	27	48	60	47	24	38.86 ± 14.08
Height (cm)	165	165	155	166	161	153	167	161.71 ± 5.62
Weight (kg)	55	65	56	70	53	54	66	59.86 ± 6.91
Affected side	Left	Right	Right	Right	Right	Right	Left	—

TABLE II. COMPARISON OF STATICS STANDING WEIGHT BEARING STEADINESS INDICES WITH AND WITHOUT STIMULATION.

	<i>Control Group (n=5) (Without Stimulation)</i>	<i>Experiment (n=5) (With Stimulation)</i>	<i>Improvement Ratio^e %</i>
HTI ^a (sec)	2.28 ± 2.16	6.23 ± 5.06	125.5
SLI ^b (mm)	206.63 ± 92.24	197.87 ± 163.97	12.95
MSDI ^c (mm)	104.72 ± 48.37	72.23 ± 40.33	31.03
ASDI ^d (mm)	55.74 ± 7.04	21.51 ± 8.05	61.41

a. HTI. (Holding time index); b. SLI. (Constant time sway length index); c. MSDI. (Maximum sway distance index);
d. ASDI. (Average sway distance index); e. Improvement Ratio= $|(\text{without stimulation} - \text{with stimulation})| / (\text{without stimulation})$

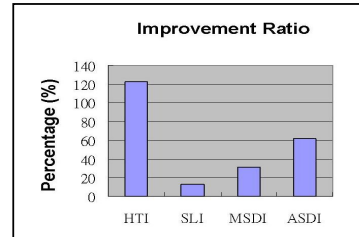

TABLE III. COMPARISON OF DYNAMIC WALKING WEIGHT SHIFTING STABILITY INDICES WITH AND WITHOUT VISUAL-AUDITORY CLUE.

	<i>Control Group (n=5) (Without biofeedback)</i>	<i>Experiment Group (n=5) (With biofeedback)</i>	<i>Improvement Ratio^e (%)</i>
DSTSI ^a (dimensionless)	0.85	0.80	5.92
CTSNI ^b (Step/min)	64.21	69.27	7.88
SSTSI ^c (dimensionless)	0.88	0.90	3.04
GPTRI ^d (dimensionless)	1.925	0.85	55.84

a. DSTSI. (Double support time symmetry index); b. CTSNI. (Constant time step number index); c. SSTSI. (Single support time symmetry index); d. GPTRI. (Gait Phase Time Ratio index); e. Improvement Ratio= $|(\text{without biofeedback} - \text{with biofeedback})| / (\text{without biofeedback})$

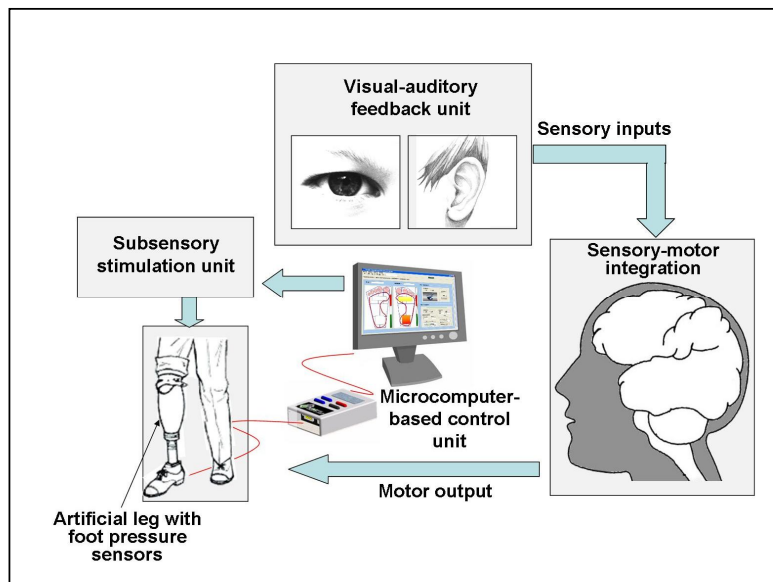

Figure 1. Illustration of conceptual design of the proposed sensory feedback system

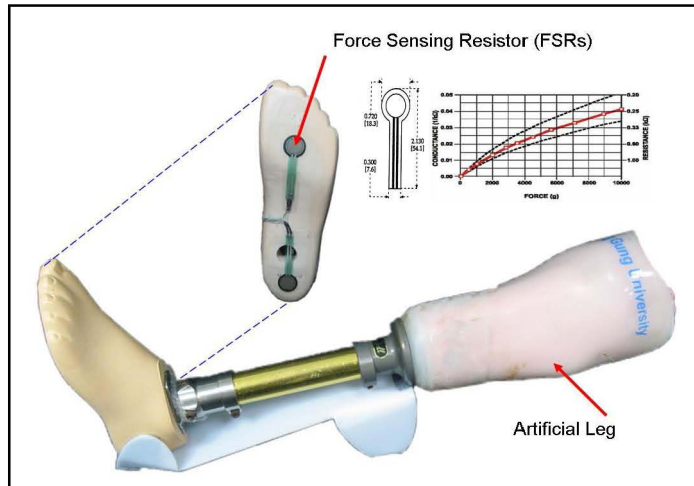

Figure 2. Force sensing resistors on artificial leg

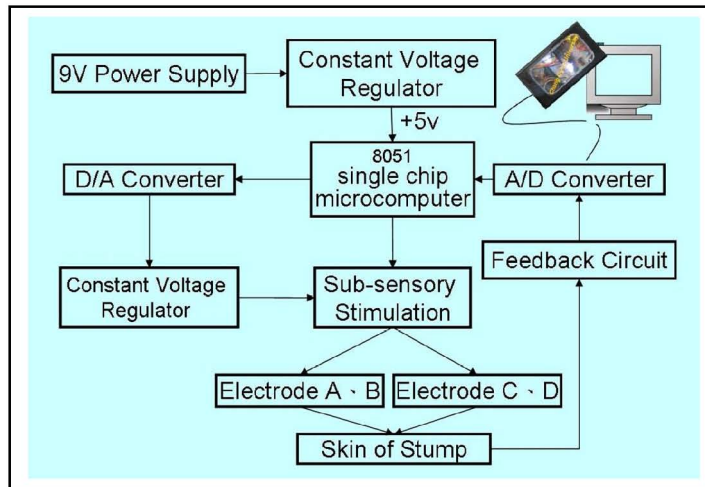

Figure 3. Flow chart of control signal in the subsensory stimulation unit

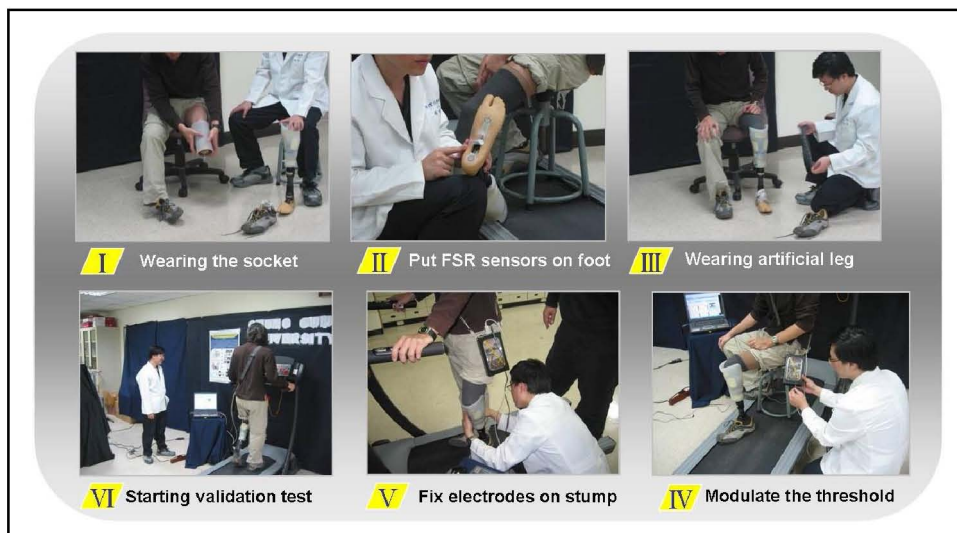

Figure 4. Experiment setup for dynamic walking weight shifting stability experiments