

Application of Neural Networks for Data Modeling of Power Systems with Time Varying Nonlinear Loads

Joy Mazumdar, *Member, IEEE*, Ganesh K. Venayagamoorthy, *Senior Member, IEEE*, and Ronald G. Harley, *Fellow, IEEE*

Abstract— Nowadays power distribution systems typically operate with nonsinusoidal voltages and currents. Harmonic currents from nonlinear loads propagate through the system and cause harmonic pollution. The premise of IEEE 519 is that there exists a shared responsibility between utilities and customers regarding harmonic control. Maintaining reasonable levels of harmonic voltage distortion depends upon customers limiting their harmonic current injections and utilities controlling the system impedance characteristics. Measurements of current taken at the point of common coupling (PCC) to a customer are expected to determine whether the customer is in compliance with IEEE 519. These measurements yield the combination of nonlinear load harmonics and nonlinear current due to supply voltage harmonics and typically the customer is required to take corrective actions to compensate the harmonics. This paper presents a neural network scheme whereby, it is possible to do data modeling of the customer's impedance and predict the resulting voltage distortion at the PCC if the customer were to take corrective actions. Experimental results from field measurements are provided. The proposed scheme is applicable to single as well as three phase systems.

I. INTRODUCTION

HARMONICS related problems on electric utility distribution systems are often created by large, primary metered, industrial customers. Typically, these problems are due to large variable speed drives and other switching type of power electronic loads. The significant harmonics are usually 5th, 7th, 11th and 13th with the 5th harmonic being the largest in most instances [1]-[3]. Classic utility-side symptoms of harmonics problems are distorted voltage waveforms, blown shunt capacitor fuses, and transformer overheating. Shunt capacitor losses are also sensitive to harmonic voltages, while transformer losses are sensitive to

This work was supported in part by the National Science Foundation and the National Electric Energy Testing Research and Applications Center (NEETRAC), USA.

J. Mazumdar and R.G Harley are with the School of Electrical and Computer Engineering, Georgia Institute of Technology, Atlanta, GA 30332 USA (phone: 404-894-5563; fax: 404-894-4641; e-mail: {joymazum}{rharley}@ece.gatech.edu).

G. K. Venayagamoorthy is with the Real - Time Power and Intelligent Systems (RTPIS) laboratory, Department of Electrical and Computer Engineering, University of Missouri, Rolla, MO 65409 USA (e-mail: gkumar@ieee.org).

harmonic currents.

Electric loads may be broadly categorized as either linear or nonlinear. A typical power distribution network contains linear as well as nonlinear loads, all connected in parallel on the low voltage side of customer service transformers. Typically the point, at which the high voltage side of a customer transformer is connected to the distribution network, is known as the point of common coupling (PCC). Nonlinear loads inject harmonic currents into the network. The interaction of the current harmonics with the network impedances creates voltage distortions [4]. The voltage at the PCC is rarely a pure sinusoid due to many other nonlinear loads in the system. As a result, measuring the current waveforms of each load yields the combination of nonlinear load harmonics and nonlinear currents due to supply voltage harmonics [5]. For example, if a purely resistive load is supplied by a distorted voltage, the load current will be distorted, appearing as if the load was nonlinear [6].

However, if a corrective action is taken by the customer, one important parameter of interest is the change in the voltage distortion level at the PCC due to the corrective action of the customer. This paper addresses this issue by predicting the change in the distortion level of the voltage at the PCC if the customer were to draw only fundamental current and filter out its harmonics. The proposed method is called *source modeling*.

The functionality of the source modeling tool is demonstrated by using the data obtained from an industrial site. Figure 1 is a single line diagram of the test site and the points where the measurements of voltage and current are recorded.

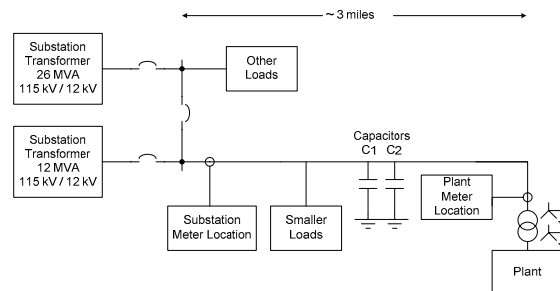

Fig. 1. Single line diagram of test site

Measurements of voltage and current are recorded at the customer's primary metering location as well as the

substation. The customer’s load (plant) in Fig. 1 is the largest load on that particular circuit with a few other customers with smaller loads. The substation has two transformers of ratings 12 MVA and 26 MVA. To establish a cleaner sinusoidal voltage at the PCC, the utility has to perform some switching of transformers to reduce the system impedance.

At the time before any switching action is performed, the customer is supplied from the 12 MVA transformer and other loads in the city as well as load from another nearby substation is supplied from the 26 MVA transformer. The two capacitor banks outside the customer’s primary meter are used for voltage control and Var compensation and were initially online. These capacitor banks are automatically controlled by voltage level. The power system configuration of the feeder circuit is a 3 phase 4 wire wye system. Two sets of measurements are taken, one at the secondary side of the substation transformer and the other at the primary side of the customer’s transformer.

The neural network source modeling scheme is demonstrated with the data acquired at the plant metering location. Waveforms of the three phase voltages (line-neutral) and the three line currents are acquired as 6 cycle snapshots, repeated at 1 minute intervals, for a period of 6 hours. Each 6 cycle snapshot measurement is designated as an event. There are 375 events recorded. Data is acquired at the rate of 256 samples per cycle. The data is downloaded from the meter to a PC running the neural network software. The recording meters used are Metrosonics PA- 9 plus [7].

II. SITE CONDITIONS

The RMS values of 3 voltages and 3 currents along with their frequency spectrums show the operating condition of the network. As an example, the RMS value of the phase A measured voltage at the customer’s primary metering location is shown in Fig. 2 and its total harmonic distortion (THD) over the entire measurement range appears in Fig. 3.

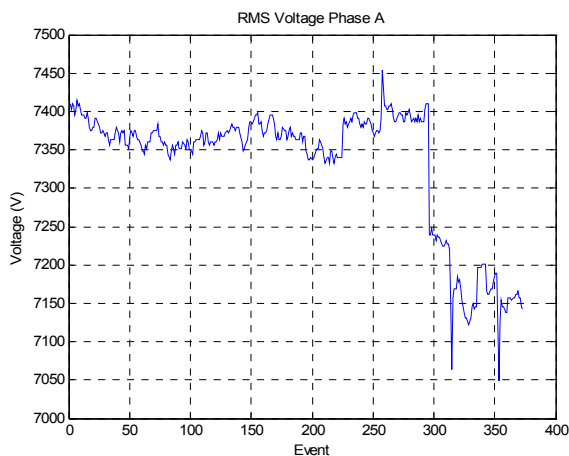

Fig. 2. RMS value of phase A (L-N) voltage

The voltage remains fairly constant until event 298, after which there is a sudden dip of 200 V. This is the impact of removing the capacitor bank C1 from the network. The second capacitor bank C2 is taken offline during event 323 and the voltage dips by another 100 V. The paralleling of the substation transformers do not have any impact on the voltage magnitude. Figure 3 reveals that the voltage THD varies from 7.5% to 2% over the entire measurement period; moreover, during event 255, when the two transformers are tied together and both capacitor banks online, the voltage THD has a sharp decrease from 7.5 % to less than 3 %. When C1 is taken offline, the voltage THD drops below 2%. This indicates a possible resonance condition between the 12 MVA transformer and the capacitor banks.

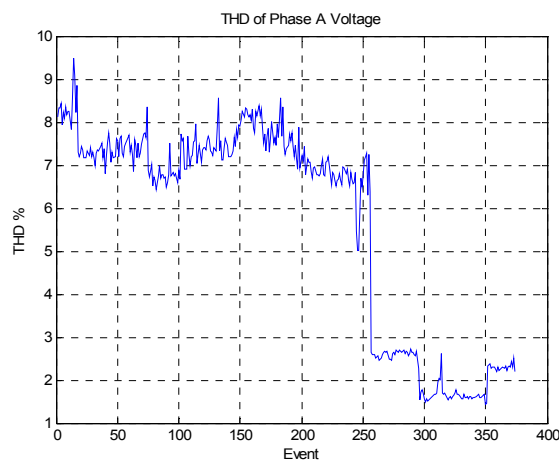

Fig. 3. THD of phase A voltage

Figure 4 shows the phase A current over the entire measurement period. The current shows the characteristics of a typical industrial plant with the load increasing and decreasing depending on the starting or stopping of machines.

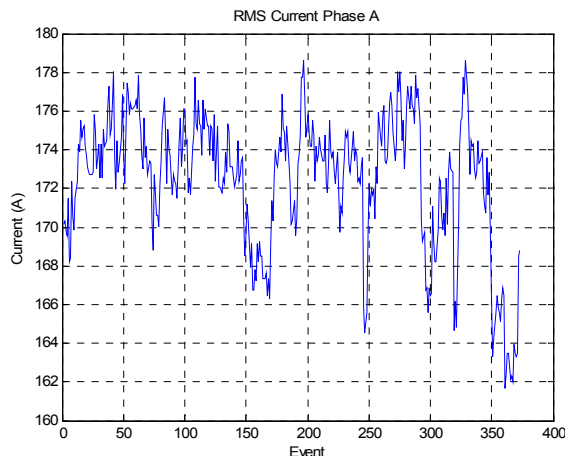

Fig. 4. RMS value of phase A current

The minimum value of current THD (Fig. 5) over the entire measurement period is 2%. This happens when both the transformers are tied together and one capacitor bank is taken offline. The impact of a customer's injected harmonics is visible when both the capacitor banks are offline after event 323.

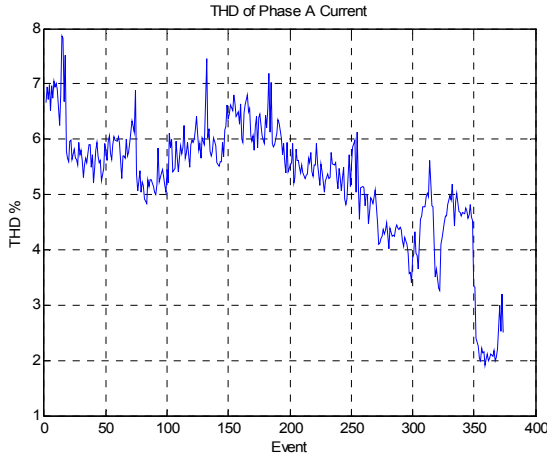

Fig. 5. THD of phase A current

The B and C phase voltages and currents exhibit similar characteristics and comparable to those of phase A. However a detailed investigation of the three phase voltages and currents are required and this is presented in the section on experimental results.

III. DESCRIPTION OF THE PROPOSED SCHEME

The proposed method predicts the change in the voltage harmonic distortion at the customer's primary metering location if the customer's load were to inject only fundamental current and were to contain no harmonics. Figure 6 is a one-line diagram of a three-phase supply network having a sinusoidal voltage source v_s , network impedance L_s, R_s and several loads (one of which is nonlinear) connected to a PCC.

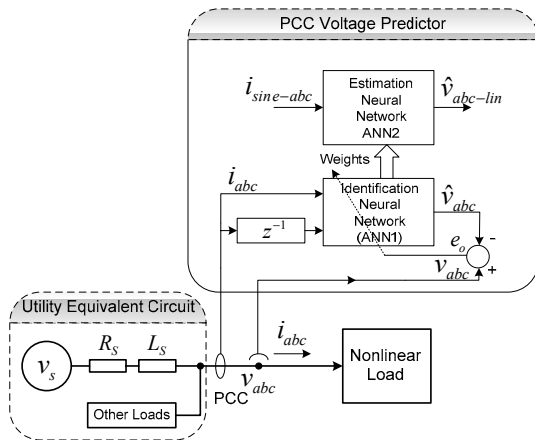

Fig. 6. Proposed source modeling scheme

The proposed method measures the instantaneous values of the three voltages v_{abc} at the PCC, as well as the three currents i_{abc} at the k^{th} moment in time. These values are fed to ANN1, which uses this to predict the values of v_{abc} at time instant $k+1$, labeled \hat{v}_{abc} . When the $k+1$ moment arrives (at the following sampling instant), and the actual values of v_{abc} are measured, these values are compared with the previously predicted \hat{v}_{abc} values, and the difference (or error e_0) is used to train ANN1 or adjust its weights. Initially, the weights have random values, but after several sampling steps, the training soon converges and the value of e_0 diminishes to an acceptably small value.

If the nonlinear load were to draw only a sinusoidal current, then the distortion level of the voltage at the PCC would change due to the absence of the load injected harmonic current. At any moment in time after the ANN1 training has converged, its weights are transferred to the Estimation neural network ANN2, and a sine wave current computed in software, is applied to its input instead of the actual measured distorted current of the nonlinear load. The output of ANN2, called $\hat{v}_{abc-lin}$, gives the same information that could have been obtained if in reality the nonlinear load were replaced by a similar sized linear load. In other words, $\hat{v}_{abc-lin}$ represents the true voltage distortion at the PCC due to the removal of all harmonic current injection by the nonlinear load in question, except that it is not necessary to actually disconnect the nonlinear load and connect a pure current source to obtain this information. Any change in the voltage distortion levels between v_{abc} and $\hat{v}_{abc-lin}$ can be attributed to the nonlinearity of the load in question.

Figure 7 shows a detailed structure of ANN1 and the training scheme. Structurally, ANN1 and ANN2 are identical.

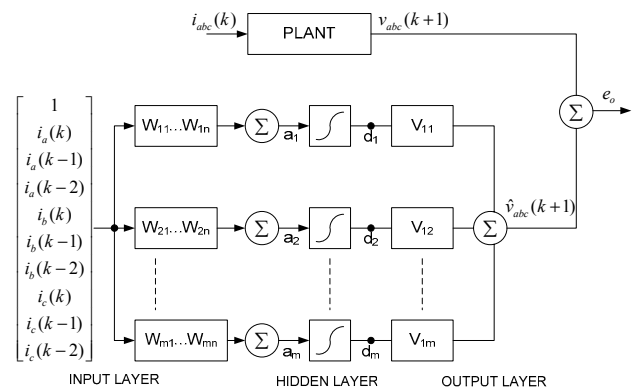

Fig. 7. Structure of ANN1 and data flow path

ANN1 and ANN2 are multilayer perceptron neural networks (MLPN) with three layers [8]. Data flows into the

network through the input layer, passes through the hidden layer and finally flows out of the network through the output layer. The network thus has a simple interpretation as a form of input-output model where the weights W and V are updated through training. Essentially, ANN1 has three line currents as inputs and the three phase voltages as outputs. However, each input also requires the present value of the current vector and two time delayed values of the current vector, as well as a bias. So the actual number of inputs to ANN1 is ten. Initially the weights have random values.

The implementation of the source modeling scheme with one identification network and one estimation network for all the three phases is illustrated in Fig. 8. The size of an MLPN is typically defined as $(n \times m \times r)$; where n is the number of neurons in the input layer, m is the number of neurons in the hidden layer, and r is the number of neurons in the output layer. For this paper, the size of ANN1 is $10 \times 20 \times 3$. Backpropagation algorithm is used for training ANN1. The error vector e_0 in Fig. 8 is a 3 element column vector and is calculated as;

$$e_0(k+1) = v_{abc}(k+1) - \hat{v}_{abc}(k+1) \quad (1)$$

The error vector e_0 is backpropagated through the network to update the network weights W and V .

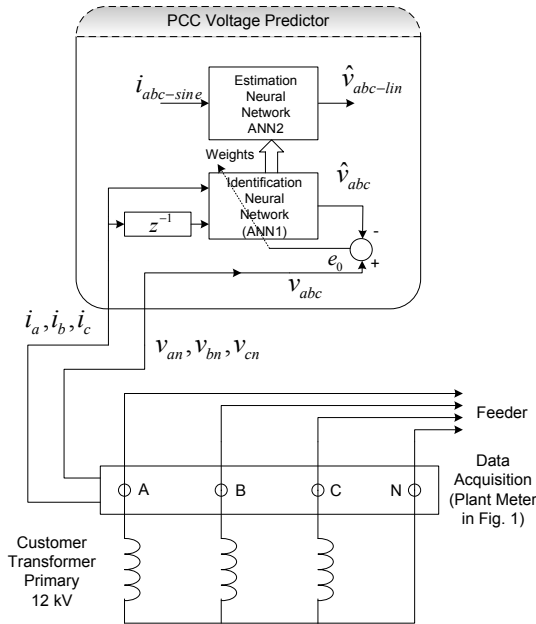

Fig. 8. Implementation of the source modeling scheme

IV. EXPERIMENTAL RESULTS

The voltages and currents acquired at the plant metering location exhibit harmonics as illustrated in Figs. 2 to 5. It is never known for sure whether the current harmonics are resulting in voltage harmonics or vice versa [9]. In the feeder circuit of Fig. 1, switching of the capacitor banks can

trigger parallel resonance and this could create voltage harmonics. Also, saturation of the customer's transformer could lead to increased current distortion. However, once the capacitor banks are offline, the voltage distortion measured at the customer's primary metering location is predominantly due the harmonic currents injected by the customer's load.

The source modeling scheme presented in this paper attempts to predict the change in the voltage distortion at the customer's primary meter if the customer's load current were to contain no harmonics. This is based on the scheme's ability to learn the impedance of the customers load.

The measurements of voltage and current are recorded simultaneously for 7 different cases of the network, at the plant as well as at the substation, as described below:

1. The customer is supplied from the 12 MVA transformer and C1, C2 are online.
2. The customer is supplied from the 12 and the 26 MVA transformers tied together, with C1 and C2 online.
3. The customer is supplied from the 26 MVA transformer and C1, C2 are online.
4. The customer is supplied from the 26 MVA transformer. At this time, C1 is switched off while C2 is online.
5. The customer is still supplied from the 26 MVA transformer and both C1, C2 are offline.
6. The customer is supplied with the 12 and the 26 MVA transformers are tied together and C1, C2 offline.
7. The customer is supplied from the 12 MVA transformer and both C1, C2 are offline.

Snapshots of the phase A voltage for event 366 (case 7) is shown in Fig. 9. During this event, both the capacitor banks are offline and the customer's load is supplied from the 12 MVA transformer.

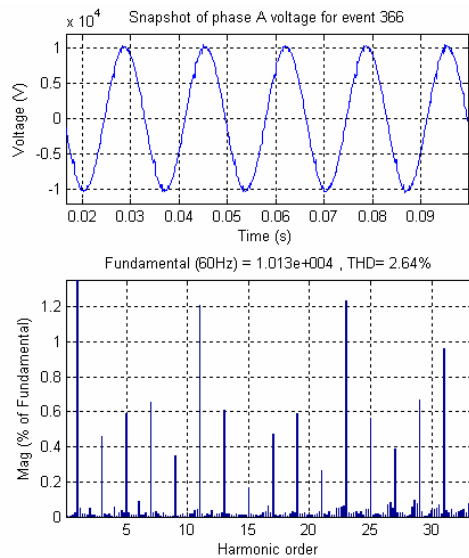

Fig. 9. Snapshot of phase A voltage

Voltage in Fig. 9 has a THD of 2.64%. Though this is within the IEEE 519 limits, it is important to note the notches in the voltage waveform due to the customer's load. The other two phases exhibit characteristics.

Table I provides the measurements recorded at the substation as well as at the customer's primary metering location for event 366. Comparison of the plant and substation meter readings for the voltage THD shows the impact of the customer's load current with the downstream impedance of the distribution circuit.

TABLE I
RECORDED MEASUREMENTS

Plant Meter Measurements (Time 15:18)				
	Voltage		Current	
	RMS (V)	THD	RMS (A)	THD
A	7160	2.64 %	159	2.12 %
B	7103	2.47 %	158	2.15 %
C	7090	2.31 %	150	2.32 %
Substation Meter Measurements (Time 15:18)				
	Voltage		Current	
	RMS (V)	THD	RMS (A)	THD
A	7501	1.42 %	234	2.13 %
B	7462	1.52 %	222	1.95 %
C	7537	1.59 %	229	1.93 %

The ANN1 of Fig. 8 is now trained with randomly selected data from the events of case 7 using backpropagation algorithm. The training continues until the value of the mean squared error e_0 of ANN1 in tracking the actual 3 phase voltages, is sufficiently low, thus indicating that the ANN1 training has been completed.

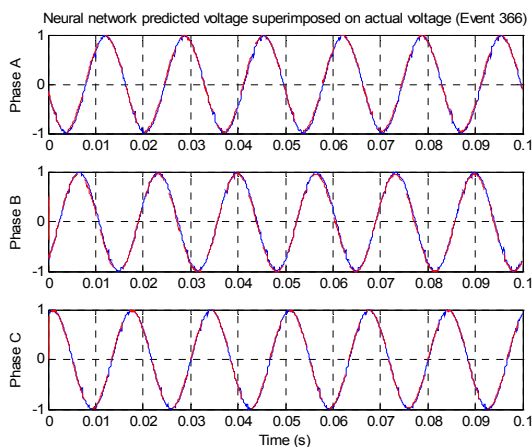

Fig. 10. Plot of ANN1 output superimposed on actual voltage

At this point, the weights of ANN1 are transferred to ANN2. Therefore, ANN2 now represents the customer's average load impedance in time domain.

Convergence in ANN1 training with data from event 366 is demonstrated by the fact that the neural network predicted voltage waveforms coincide with the actual voltage as shown in Fig. 10 and by the decrease in MSE in Fig. 11.

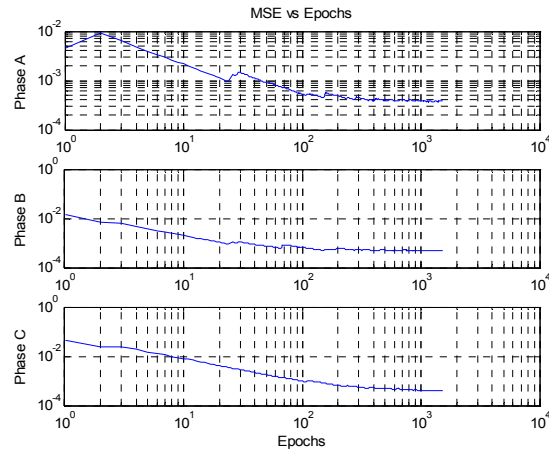

Fig. 11. Training performance of ANN1 in terms of MSE

ANN2 is now supplied with a balanced 3 phase mathematically generated sine wave representing the customer's current with no harmonics. The outputs of ANN2 in Figs 12 to 14 are the predicted voltage waveforms that would be expected at the PCC if the customer were to apply filtering techniques to clean up the harmonic currents which it was injecting into the network. The predicted voltage waveforms are then compared with the actual measured voltages of event 366 (Table I) to determine the difference that the customer's filtering action will have on the voltage distortion at the PCC.

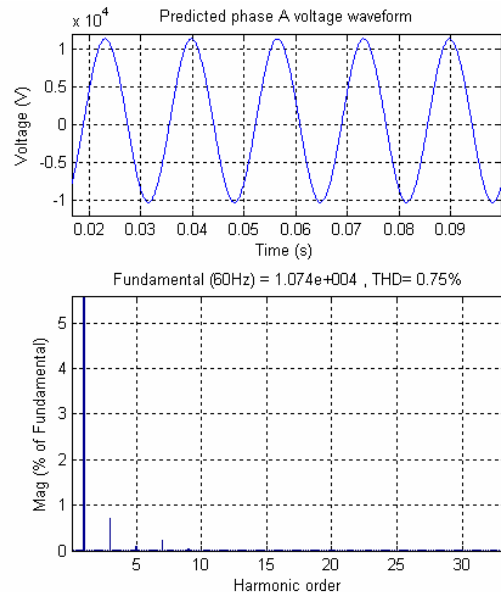

Fig. 12. Plot of phase A voltage predicted by ANN2

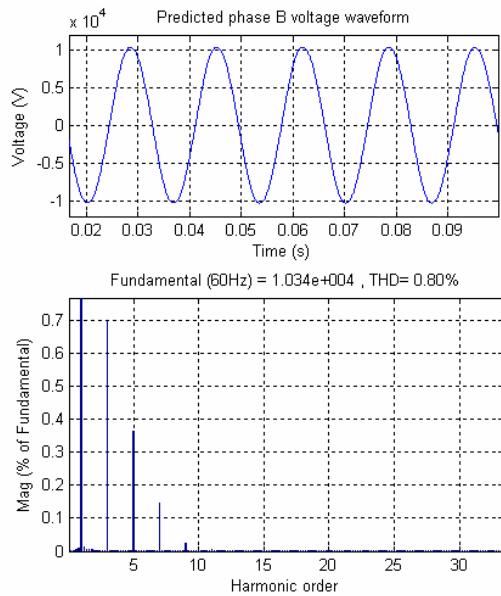

Fig. 13. Plot of phase B voltage predicted by ANN2

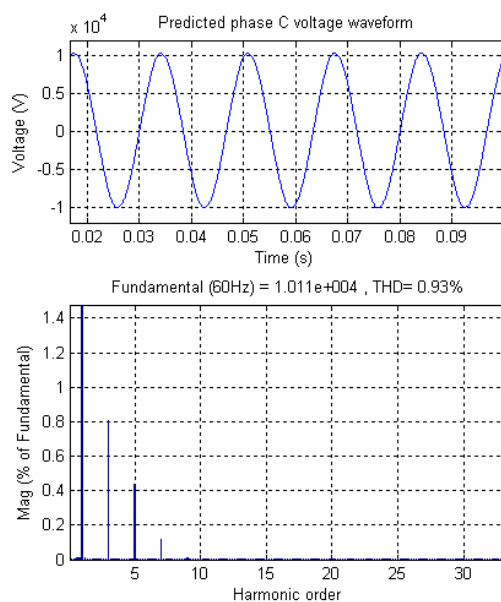

Fig. 14. Plot of phase C voltage predicted by ANN2

The ANN2 predicted voltage waveforms have THD less than 1%. This is expected as the customer’s load is the dominant load on the feeder circuit and is nonlinear in nature. The other loads on this feeder circuit are residential customers. The customer’s load is primarily composed of thyristor controlled drives. The commutation of the thyristors creates notches on the supply voltage and that is seen in Fig. 9. The characteristic current harmonic injected by these drives is the 5th harmonic. Once the customer’s current is assumed to be a clean sine wave, there are no sources of distortion and the voltage THD’s reduce from the values measured in event 366.

A comparison of the measured voltage THD and predicted voltage THD for all three phases at the PCC is presented in Table II.

TABLE II
COMPARISON OF THE VOLTAGE THD’S

Phase	Measured Voltage THD (Event 366)	ANN2 Predicted Voltage THD
A	2.64 %	0.75 %
B	2.47 %	0.80 %
C	2.31 %	0.93 %

To give a quantitative meaning to the THD values predicted by ANN2, a percentage change is computed as;

$$\frac{(Measured\ Voltage\ THD - Predicted\ Voltage\ THD)}{Measured\ Voltage\ THD} \times 100\% \quad (2)$$

For this particular site, the phase A voltage THD reduced by 71.5%, phase B voltage THD reduced by 67.6% and phase C voltage THD reduced by 59.7%.

V. CONCLUSIONS

This paper demonstrated the ability of the source modeling scheme to predict the change in the voltage distortion at the PCC due to the implementation of corrective filtering actions by a customer. The paper also shows the feasibility of applying the proposed scheme to actual field data and the possibility of training the neural network with snapshot data.

The largest benefit of the source modeling scheme is that it is possible to obtain results and draw conclusions regarding the impact of a customer’s harmonic current injection without the need for the customer to actually take the corrective actions. Due to the phenomenon of harmonic cancellations, it is also possible that corrective actions by a customer may actually deteriorate the voltage distortion levels at the PCC. The source modeling scheme is designed in software and hence can be integrated into any commercially available power quality diagnostic instrument.

ACKNOWLEDGMENT

Georgia Power is thanked for providing the field data and technical help required for this report.

REFERENCES

- [1] IEEE Power System Harmonic Working Group, “Bibliography of Power System Harmonics, Part I and II,” in Proceedings of the IEEE PES Winter Power Meeting 1984, pp. 2460 – 2479, Jan/Feb 1984.
- [2] IEEE Standard 519-1992, IEEE Recommended Practices and Requirements for Harmonic Control in Electric Power Systems.

**Proceedings of the 2007 IEEE Symposium on
Computational Intelligence and Data Mining (CIDM 2007)**

- [3] S. Bhattacharya, D. Divan and B. Banerjee, "Synchronous frame harmonic isolator using active series filter," *EPE-Firenze*, Vol. 3, pp. 30-35, 1991.
- [4] Chun Li, Wilsun Xu, and T. Tayjasanant, "A Critical Impedance Based Method for Identifying Harmonic Sources", *IEEE Transactions on Power Delivery*, Vol. 19, Issue: 2, April 2004, pp. 671 –678.
- [5] K. Srinivasan, "On Separating Customer and Supply Side Harmonics," *IEEE Transactions on Power Delivery*, Vol. 11, Issue 2, pp. 1003 - 1012, April 1996.
- [6] J. Mazumdar, R. Harley and F. Lambert, "System and method for determining harmonic contributions from non-linear loads," in *Proceedings of the IEEE Industry Applications Society Annual Meeting (IAS 2005)*, Hongkong, vol. 4, pp. 2456-2463, Oct 2 – 6, 2005.
- [7] <http://www.megger.com>
- [8] B. Burton and R.G. Harley, "Reducing the computational demands of continually online-trained artificial neural networks for system identification and control of fast processes", *IEEE Transactions on Industry Applications*, Vol. 34, Issue: 3, pp. 589 – 596, May/June 1998.
- [9] W. Xu, and Y. Liu, "A Method for Determining Customer and Utility Harmonic Contributions at the PCC," *IEEE Transactions on Power Delivery*, Vol. 15, Issue 2, pp.804-811, April 2000.