

# SMART DIFFERENTIAL PRESSURE SENSOR

Michal Pavlik, Jiri Haze, Radimir Vrba and Miroslav Sveda  
Brno University of Technology, Udolni 53, CZ-60200 Brno, Czech Republic  
pavlik.michal@phd.feec.vutbr.cz, haze@feec.vutbr.cz, vrbar@feec.vutbr.cz, sveda@fit.vutbr.cz

**Keywords:** Pressure measurement, ultra-low power application, current loop, microcontroller overclocking, non-linear interpolation.

**Abstract:** This paper presents design and assembly of mixed electronic circuitry for measured signal processing of the capacitive difference pressure sensor, as well as analysis of the obtained results. The smart pressure sensor provides values of measured pressure via 4 - 20 mA current loop output. The loop current is also used for sensor circuitry supplying. This means that current consumption of the whole sensor electronics should be less than 3.5 mA even in extended industrial temperature range from -40 to +125 °C.

## 1 INTRODUCTION

There are needs in some industrial branches to measure difference between two pressures. The differential measurement system is frequently used for pressure measurements because of its good temperature and time stability. The internal schematic diagram of the differential pressure sensor can be analyzed is a pair of capacitors sensing to differential pressure actual values. These capacities can be up to tens of picofarads. There is no direct measuring of capacities, but capacities of measured capacitors are converted to actual output frequency of a pair of frequency oscillators controlled by measured capacitors. The most important issue is the precision of measurement. Total accuracy is required to be better than that equivalent to 16 binary bits resolution. Therefore frequency of 255 periods of the output signal is averaged. The aim of this paper is the description of the low-power and high-precision measuring system design.

## 2 ELECTRONICS TOPOLOGY

The proposed electronic circuitry of the pressure sensor can be split into three modular parts. Signal processing of the differential pressure sensor is realized by a pair of oscillators whose output frequencies reflect the value of the measured pressure. Consequently, galvanically separated part including microcontroller converts the output

frequency values of the oscillators to digital code values. Besides, embedded microcontroller calculates non-linear correction of the measured values and temperature calibration at the same time. The output quantity of this part of electronic circuitry is a digital calibrated value of pressure. According to the desired extended temperature range from -40 to + 125 °C of the proposed sensor, the outputs of the oscillators are carried by signal transformers.

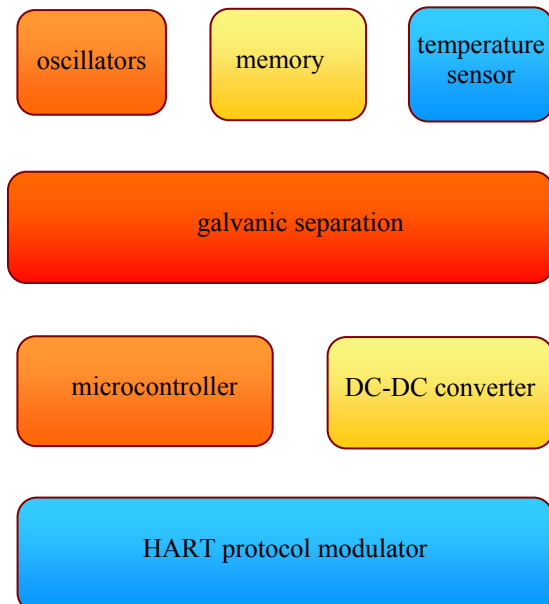

Figure 1: Block diagram of system topology.

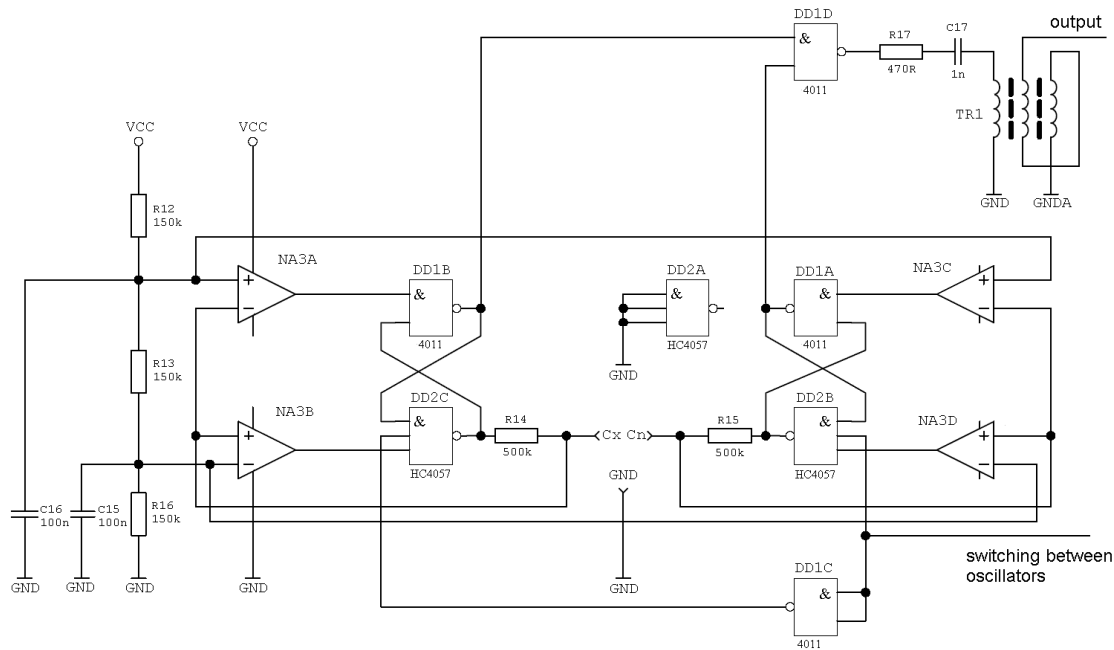

Figure 2: Simplified schematic diagram of galvanically separated oscillators.

The microcontroller controls galvanically separated DC-DC changer that supplies oscillators, too. The block diagram of the electronic circuitry topology is shown in Fig. 1. A microcontroller is included in the third part of electronics. The microcontroller is mainly used for HART modulation of the loop current communication. The second function of the microcontroller is active regulation of the actual current in the current loop by means of sensor consumption supplying current control. Interconnection between the second and third stage of electronics is provided by the SPI bus. These two parts are galvanically connected.

## 2.1 Oscillators

Even if oscillators are based on the two basic 555 circuits, there are a few circuitry modifications. Only one of oscillators is running during actual running phase of the measurement process. It results in decreasing power consumption to nearly 65% of the original one. The ultra low power and fast comparators MAX939 are used. The crucial parameters of the comparators are slew rate and transfer time delay. The application of these comparators represents the best solution in terms of power consumption and speed ratio. The precision of the measurement mainly depends on the reaction time of the comparators or possibly on the spread of

the overshoot from the reference voltage. The simplified schematic diagram of the oscillators is shown in Fig. 2. Output signal of the running oscillator is led via serial combination of the capacitor and resistor to a primary winding of a signal transformer. Serial resistor limits flowing surge current when the logic output is changed. Unfortunately, restriction of an exciting current leads to extension of the rising and falling edge of the transmitted signal. Serial capacity prevents bias direct current from passing the transformer, thus protects the transformer against overloading. The output frequency of the oscillators can be calculated using a simple equation

$$f_{out} = \frac{2 \cdot R}{C}, \quad (1)$$

where  $R$  is value of reference resistor 500 k $\Omega$  and  $C$  represents the measured capacity.

## 2.2 DC-DC Changer

The DC-DC changer with a transformer was designed to supply the oscillators. The transformer provides galvanic separation. In reality, construction of the switched changer was the only one possible solution and efficiency better than 50 % was achieved. The circuitry of the changer consists of a minimum component and is driven by an embedded microcontroller. Unfortunately, the feedback cannot

be used because it leads to increased power consumption.

### 2.3 Measurement Principle

The measurement is based on counting of 255 periods of the measured signal. Microcontroller system clock is used as a sampling signal. Quiescent frequency of the oscillators is set to 4.5 kHz. The microcontroller counts 255 periods in 56 ms. Thus total measurement time is 112 ms. These calculations are not correct because the pair of oscillators are not really identical, but even if real measurement can be faster or slower, complete measurement time is constant. This attribute is given by design of the differential pressure sensor. The measurement algorithm is implemented in the microcontroller as follows: Counter/Timer0 (C/T0) is configured as an 8-bit counter (it means 255 period of input signal). The Counter/Timer1 (C/T1) runs as a 16-bit timer with 125 kHz clock before the counting is allowed. The low system frequency of the microcontroller significantly reduces power consumption [3]. But minimal 1 MHz of the system frequency is needed to suppose desired measurement accuracy. Due to when 253 periods are counted the microcontroller is over-clocked to 2 MHz. The value in C/T1 is stored for next processing and C/T1 is cleared. When the 255 periods are counted, the interrupt is called and value in C/T1 is read. This value reflects the measured capacity. With no pressure the counter counts approximately 112 000 pulses from each oscillator. By using equation

$$n = \frac{\log x}{\log 2}, \quad (2)$$

where  $x$  represents numbers of levels and  $n$  is a bit resolution, we can calculate that we can measure oscillator frequencies with more than 16-bit resolution.

This accuracy is adequate. For effective processing of the measured values, the working variable  $A(p)$  is evaluated. Variable  $A(p)$  represents uncorrected digital pressure

$$A(p) = \frac{f_1 - f_2}{f_1 + f_2}, \quad (3)$$

where  $f_1$  and  $f_2$  are measured frequencies of oscillator output signals. At next stage the working variable  $A(p)$  is calibrated using non-linear corrections by hi-order polynomial. The calibration provides linear response of the output value to the pressure. The calibrated output value presents the digital pressure and is set in specified units (bar, kPa, etc.). After all linearization and calibration processes the value is sent via SPI to the second

microcontroller which provides transmitting into the current loop.

### 2.4 Corrections

Two corrections are calculated by the embedded microcontroller. At first, the linearization, offset calibration and gain correction are calculated. Next, the temperature dependence of the measuring electronics is compensated. Fig. 3 shows enumerated dependencies in a 3D graph.

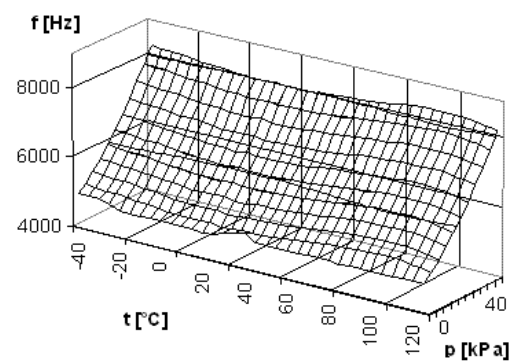

Figure 3: The oscillator output frequency dependence on pressure and temperature.

There are a few calibration methods for example lookup tables but these methods are usually of a high cost and time consuming [2]. The polynomial of fifth to eighth order is used for calibration of the variable  $A(p)$ . The basic form of the polynomial is

$$y = a_0 + a_1x + a_2x^2 + \dots + a_nx^n \quad (4)$$

The Lagrange's polynomial is used for calculation of the calibration constants. The Lagrange's polynomial is the lowest order polynomial which goes through specified values [4]. The Lagrange's polynomial can be calculated by

$$\sum_{i=1}^n f(x_i) \lambda_i \quad (5)$$

where

$$\lambda_i = \frac{(x - x_1)(x - x_2) \dots (x - x_{i-1})(x - x_{i+1}) \dots (x - x_n)}{(x_i - x_1)(x_i - x_2) \dots (x_i - x_{i-1})(x_i - x_{i+1}) \dots (x_i - x_n)}. \quad (6)$$

The calibration data is stored in FRAM embedded on the oscillator board.

### 2.5 HART Protocol

For communication over the 4 - 20 mA current loop, the HART protocol is used [1]. Signal current modulation is provided by the second microcontroller. Transmitting is done using controlled loading. The regulated loading circuitry is very simple and consists of an NPN type bipolar transistor with a grounded emitter and a driving DA converter. Current consumption is minimized thanks to simplicity of the regulated loading.

### 3 RESULTS

After design, assembly and programming of the microcontroller real measurements were done. The frequencies of the oscillators, working variable  $A$  and digital pressure values were logged. These values were logged for many different pressures over the whole sensor range. From the measured data the bias noise was figured out by equation

$$N_f = \frac{\Delta N_{\max}}{N_{\max} - N_{\min}}, \quad (7)$$

where  $\Delta N_{\max}$  represents the maximal deviation from the mean value of a few samples for a specified pressure in the whole measuring range,  $N_{\max}$  is value of the output with maximal pressure and  $N_{\min}$  is value of the output with no pressure.

The bias noise in the whole measuring range was only 0.82 ‰. By conversion of the bias noise to the bit resolution the 13.57 effective bit resolution was achieved. The linearity degree of the working variable which determines order of the correction polynomial is very important. The dependence of the variable  $A(p)$  on pressure is shown in Fig. 4.

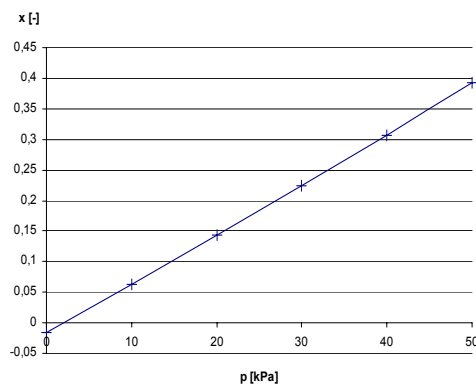

Figure 4: Dependence of the measured output on the pressure.

We can observe deviations of the measured waveform in Fig. 5.

And finally, deviation of the corrected waveform is shown in Fig. 6, after calculating of the Lagrange polynomial constants and their application from the linear waveform.

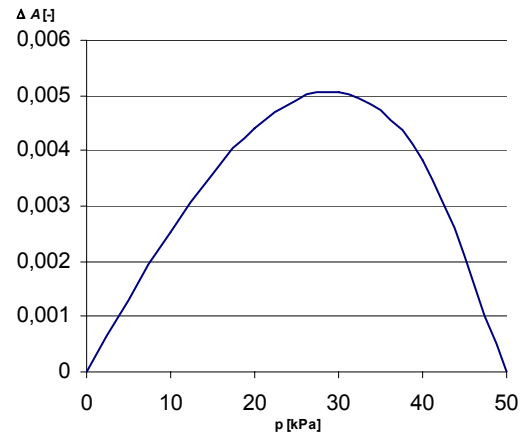

Figure 5: Deviations of the measured waveform.

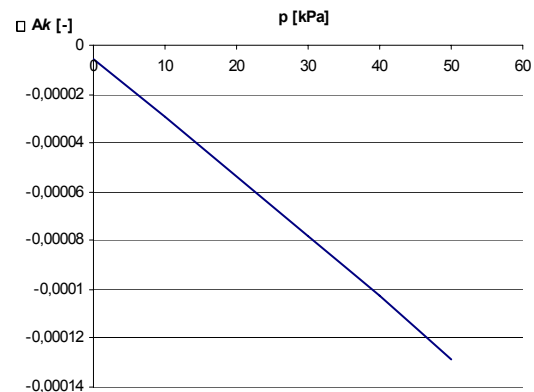

Figure 6: Deviations of the calibrated waveform.

### 4 CONCLUSIONS

A smart differential capacity pressure sensor was designed and assembled. The system consists of three parts – oscillators, processing microcontroller and HART modulator. Ultra low-power devices and special measuring algorithm in microcontroller were used to reduce power consumption bellow 3.5 mA. The Lagrange polynomials were applied to calculate

the measured values calibration. It improves linearity more than ten times.

## ACKNOWLEDGEMENTS

The research has been supported by the Czech Ministry of Education within the framework of the Research Program MSM0021630503 MIKROSYN, by the Czech Grant Agency in projects GACR 102/03/0619 and GACR 102/03/H105, and by the Ministry of Industry and Commerce in projects FF-P/112 and FT-TA/050.

## REFERENCES

- HART communication foundation (2007) *HART specification*,  
[http://www.hartcomm2.org/hart\\_protocol/protocol/hart\\_specifications.html](http://www.hartcomm2.org/hart_protocol/protocol/hart_specifications.html)
- Kouider, M. Nadi, M. and Kourtiche D. (2003) *Sensors Auto-calibration Method - Using Programmable Interface Circuit Front-end*, SENSORS 2003, ISSN 1424-8220
- Holberg, A.M. and Seatre A. (2006) *Innovative Techniques for Extremely Low Power Consumption with 8-bit Microcontrollers*, ATMEL White Paper
- Mori, H. and Yamada S. (2003) *Continuation Power Flow with the Nonlinear Predictor of the Lagrange's Polynomial Interpolation Formula*, IEE Japan