

LOSS MINIMIZATION OF INDUCTION GENERATORS WITH ADAPTIVE FUZZY CONTROLLER

Durval de Almeida Souza*, José Antonio Dominguez Navarro**

* Federal Center for Technology Education of Bahia – CEFET-BA/ UE de Vitória da Conquista
3150 Zabelê, 45030-220, Vitória da Conquista, Bahia, Brazil
durval@cefetba.br

Jesús Sallán Arasanz

** University of Zaragoza, Department of Electrical Engineering, Calle Maria de Luna s/n
50018 Campus del Actur, Zaragoza, Spain
jadona@unizar.es, jsallan@unizar.es

Keywords: Inverter-fed induction generator, loss minimization, vector control, fuzzy controller, adaptive control.

Abstract: In this paper a new technique for efficiency optimization of induction generator working at variable speed and load is introduced. The technique combines two distinct control methods, namely, on-line search of the optimal operating point, with a model based efficiency control. For a given operating condition, characterized by a given turbine speed (ω_T) and electric torque (T_e), the search control is implemented via the “Rosenbrock” method, which determines the flux level that results in the maximum output power. Once the optimal flux level has been found, this information is used to update the rule base of a fuzzy controller, which plays the role of an implicit mathematical model of the system. Initially, for any load condition the rule base yields the rated flux value. As the optimum points associated with the different operating conditions are identified, the rule base is progressively updated, so that the fuzzy controller learns to model the optimal operating conditions for the entire torque-speed plane. After every rule base update, the Rosenbrock controller output is reset, but it is kept active to track possible minor deviations of the optimum point.

1 INTRODUCTION

In the last decade, wind power is integrated into the electrical grid and accounts for a noticeable share of the total power generation (Kumar, 2007). In this context the inverter-fed induction generator has been identified as a possible source of energy to be used in modern micro and high power applications (Leidhold, 2002). The presence of a converter in a drive system enables an extra degree of freedom, namely, flux adjustment. In fact, efficiency optimization in adjustable speed drives is usually obtained by machine flux control. This is due to the fact that in electric machines, maximum efficiency is achieved when the copper losses become equal to the core losses. Typically, under partial load operation, rated flux condition results in relatively large core losses, small copper losses, and poor efficiency. By decreasing the flux, core losses are reduced, whereas an increase in copper losses takes

place. The total losses, however, are reduced, and the efficiency is improved (Sousa, 1995). In this work, a new efficiency optimization technique is introduced. It is applicable to any adjustable speed drive, but it is illustrated here for an induction generator under field-oriented control. The technique combines two distinct control strategies, namely, on-line search and model base control. For a given operating condition, characterized by a given turbine speed (ω_T) and electric torque (T_e), the search control is implemented via the Rosenbrock method, which determines the flux level that results in maximum output power. Once the optimal flux level has been found, this information is used to update the rule base of a fuzzy controller, which plays the role of an implicit mathematical model of the system. Figure 1 shows the scheme of the Inverter-Fed Induction Generator used in this research.

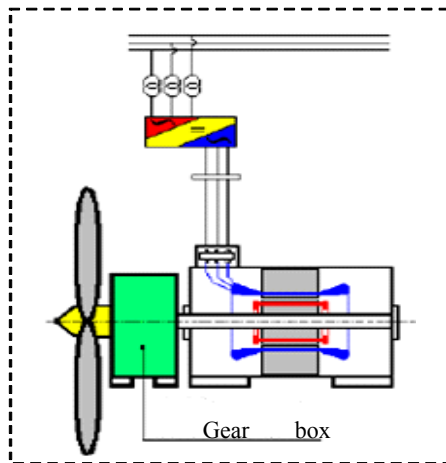

Figure 1: Inverter-fed induction generator connected to grid. Figure adapted by (Rüncos).

2 EFFICIENCY OPTIMIZATION

2.1 Search Control

In steady state with constant torque and speed, the flux component of the chain is decreased whereas the torque component is increased. Initially a reduction in total stator current occurs ($I_s = i_{qs} - j i_{ds}$), and consequently a reduction in stator copper losses, but rotor copper losses are increased. As the reduction in both stator and iron losses are higher than the increase in rotor losses, the total losses are reduced. If i_{ds} is continuously reduced, a reduction in the total losses will occur until the moment when the increase in copper losses becomes higher than the reduction in core losses, that is, the point minimum losses will be exceeded. The determination of this point, of minimum losses, that corresponds to optimum efficiency, can be performed using different procedures. This philosophy is illustrated in figure 2.

A turbine is submitted to a load proportional to the square of the angular speed of the wind. Thus, in weak wind conditions, below 7 m/s, the generator works typically with light rotor load. In such conditions the intensity of the rotor flux of the induction generator (IG), commanded in vector control for i_{ds} , can be reduced to values below nominal flux, reducing reactive circulation, diminishing iron losses and consequently increasing global efficiency of both inverter and machine (Sousa,1995), something essential at low wind speed to improve power extraction capacity, (Simões, 1999).

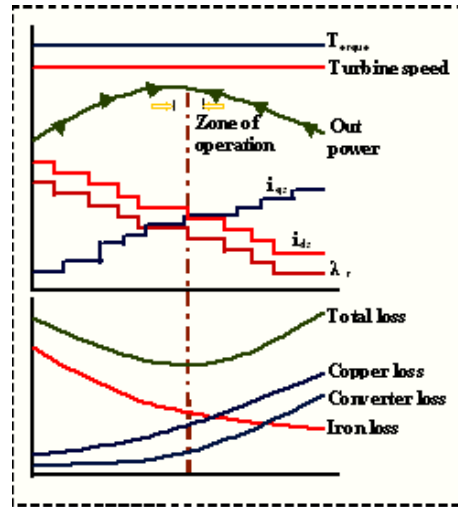

Figure 2: Philosophy for search method of efficiency optimization.

As mentioned before, rated flux results in excessive core losses and poor efficiency under light load conditions. Another aspect worth mentioning is the need to prevent machine torque disturbances during the efficiency optimization control. Under vector control, the developed torque can be expressed as:

$$T_e = k_t \lambda_r i_{qs} \quad (1)$$

where: λ_r is the rotor flux and i_{qs} is the torque component of the stator current, and k_t is a constant. If the flux is reduced to improve efficiency, i_{qs} must be increased accordingly, such that their product remains constant at any given time.

2.1.1 The Rosenbrock Method

This is a very simple method, and guaranteed to converge. The reference for the flux component of the stator current (i_{ds}^*) is modified in small steps in a given direction, while the system approaches the optimum efficiency point, i.e., the measured change in output power in the n -th step is positive ($\Delta P(n) > 0$). When the method recognizes that an “overshoot” has occurred ($\Delta P(n) < 0$), it reverses the search direction, with a reduced step size, (J. Moreno-Eguilaz, 1997). The search process can be mathematically expressed as in (2):

$$i_{ds}^*(n+1) = i_{ds}^*(n) + k \Delta i_{ds}^*(n); \quad \begin{cases} k=1; & \text{if } \Delta P(n) > 0 \\ k=-\frac{1}{2}; & \text{if } \Delta P(n) < 0 \end{cases} \quad (2)$$

where: $\Delta P(n) = P(n) - P(n-1)$ and $\Delta i_{ds}^*(n) = i_{ds}^*(n) - i_{ds}^*(n-1)$.

3 THE PROPOSED SYSTEM

The indirect method of vector control is applied to the IG. It derives the reference for the torque component of the stator current (i_{qs}^*) from the speed error, utilizing a conventional proportional-Integral (PI) controller. As the system operates with variable flux, a compensation block is introduced at the output of the speed PI controller. Essentially, this block multiplies the original PI controller output by the ratio rated flux / actual flux (estimate).

The reference for the flux component of stator flux (i_{ds}^*) is not kept constant here, as in the majority of high performance IM drive systems. It is defined as the sum of two block outputs: $i_{ds}^*(k) = i_{ds}^{*'}(k) + \Sigma\Delta i_{ds}^{*}$. The first term (i_{ds}^{*}') is obtained from a fuzzy controller, that from two inputs (speed (ω_r) and estimate load torque(T_L), derives a preliminary reference (i_{ds}^{*}') through fuzzy inference. The second one ($\Sigma\Delta i_{ds}^{*}$) is the actual output of a search controller, based on the Rosenbrock method. Its value represents the accumulated control actions taken by the controller during the search process up to the current iteration (n), as can be seen in Fig. 3.

When the system is turned on for the first time, the rule base of the fuzzy controller contains rated d-axis current reference (i_{ds}^{*}) for all rules, i.e. for any speed and load torque point. When a steady state condition is detected, the search controller becomes active. After a few steps, it reaches the optimum efficiency point by imposing the $\Sigma\Delta i_{ds}^{*}$ change to the original reference (i_{ds}^{*}) from the fuzzy controller. Once the controller recognizes this optimum condition, the rule base can be updated to reflect the knowledge of the optimum flux level for this particular operating point (load torque and speed). At the same time, the search controller output must be reset, to prevent erroneous operation. When the optimum point is found, the rule base is updated, and the output of the search controller reset, such that, effectively, $i_{ds\ opt}^* = i_{ds}^{*}$.

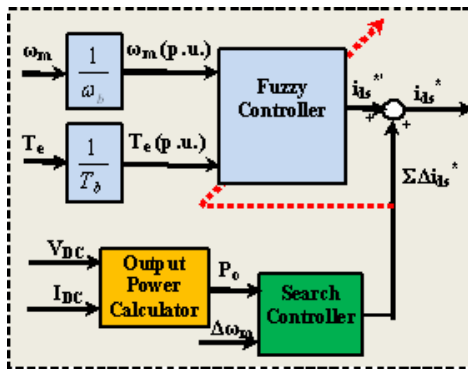

Figure 3: Hybrid efficiency controller.

As the optimum efficiency points related to the several operating conditions are identified, the rule base is progressively updated, such that the fuzzy controller “learns” the optimum flux level for the entire torque-speed plane. Once completed the learning process, the output of the fuzzy controller already reflects the optimum flux level, and the fuzzy controller is capable of driving the system at optimum efficiency without delays. To prevent sub-optimal operation, the search controller remains active to track possible deviations of the optimum point. Under transient conditions, the search process is cancelled, and the flux reference is solely derived from the fuzzy controller. It is worth noticing that no switching of strategies is required, since higher torques demands are normally met by imposing higher flux levels, i.e., the optimum level of flux for higher torques is close to the rated flux value. This methodology is summarized in Figure 4.

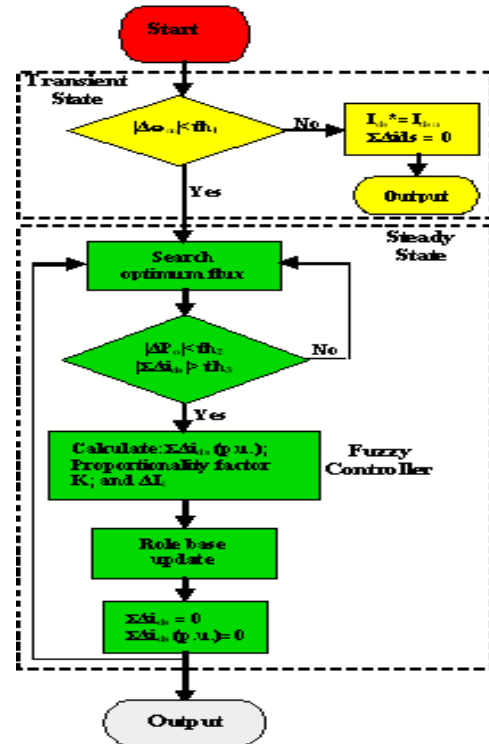
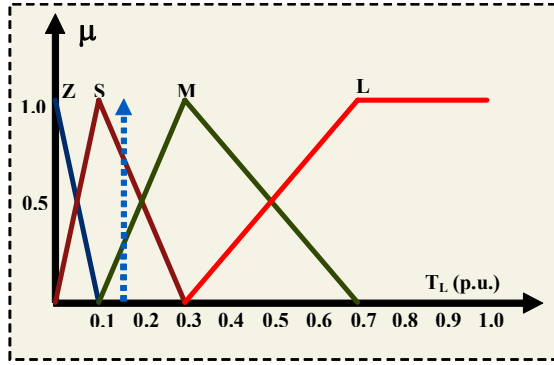

Figure 4: State diagram for efficiency controller.

3.1 The Fuzzy Efficiency Controller

The fuzzy sets for the input variables are shown in Figure 5. Both utilize normalized universes of discourses, to make the controller easier to port for different machine ratings. The output variable (i_{ds}^{*}) is represented by singletons, and is not shown here. The rule base for the fuzzy controller is illustrated in

Table 1. It is typically initialized with rated i_{ds}^* (1 p.u.), and it is progressively updated to incorporate the knowledge of the maximum efficiency points as they are found by the search controller, as previously described.



(a)

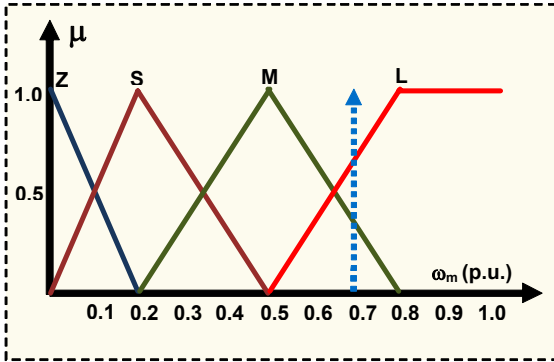

(b)

Figure 5: Fuzzy sets for the input variables: (a) load torque and (b) speed.

Table 1: Rule base for the fuzzy controller.

$T_L \backslash \omega_m$	Z	S	M	L
Z	1	1	1	1
S	1	1	$I_{A(n+1)}$	$I_{B(n+1)}$
M	1	1	$I_{C(n+1)}$	$I_{D(n+1)}$
L	1	1	1	1

The primary flux reference current i_{ds}^* is obtained by fuzzy sup-min inference, and the height method of defuzzification:

$$i_{ds}^* = \frac{\sum_{i=A}^D I_{i(n+1)} \times \mu_{Ri}}{\sum_{i=A}^D \mu_{Ri}} \quad (3)$$

At steady state condition, whenever the search controller identifies an optimum flux level, the rule base must be updated. This process can be summarized as follows:

1) Identify the fired rules in the Rule Base (e.g., rules A,B,C,D in Table 1);

2) Compute the degree of truth for each rule, by applying the minimum (min) operator over the degree of membership for the input variables T_L and ω_r : $\mu_{Ri} = \min(\mu_{T_L}, \mu_{\omega_r})$;

3) Evaluate the proportionality factor K , given by (4);

$$K = \frac{\sum_{i=A}^D \mu_{Ri} \times \sum \Delta i_{ds} (pu)}{\sum_{i=A}^D \mu_{Ri}^2} \quad (4)$$

4) Compute the correction term $\Delta I_i(n) = K \times \mu_{Ri}$ for each fired rule as the product of its degree of truth and factor K ;

5) Get the new value for each fired rule i ($i=A,B,C,D$) by (5).

$$I_i(n+1) = I_i(n) + \Delta I_i(n) \quad (5)$$

3 SIMULATION RESULTS

In this simulation a 4 kW squirrel-cage induction machine was used (220/380V, $p=2$). A reference speed step of 0.88 p.u, 0.40 p.u, 0.88 p.u and 0.40 p.u is applied at $t=1s$, $t=30s$, $t=45s$ and $t=55s$, respectively, as shown in Figure 6 (A). After the initial transient, at $t=6s$, the search begins. At $t=15s$ the controller identifies that an optimum point has been found, and proceeds to update the rule base. Up to this point, the output of the fuzzy controller (i_{ds}^*) was the rated value for magnetizing current, but from this time on, its output is made equal to the optimum value. Simultaneously, the output of the search controller is reset ($\sum \Delta i_{ds} = 0$), as can be seen in Figure 6 (B). The rotor flux response follows a first order filter profile of the reference current (i_{ds}^*) as expected, and is shown here multiplied by a factor of 10, Figure 6 (C). The changes in flux level have a direct impact on the output power, Figure 6 (E), as well as in the torque component of stator current reference (i_{qs}^*), as expected, but the electromagnetic torque is unaffected, due to proper feed-forward compensation in i_{qs}^* , as shown in Figure 6 (D). At $t=45s$ and $t=55s$ when a previous reference speed step is applied, the rule base recognize and the system operate directly with optimum efficiency. Figures 6 (F) and (G) shown the voltages and currents on the phases A, B and C, respectively.

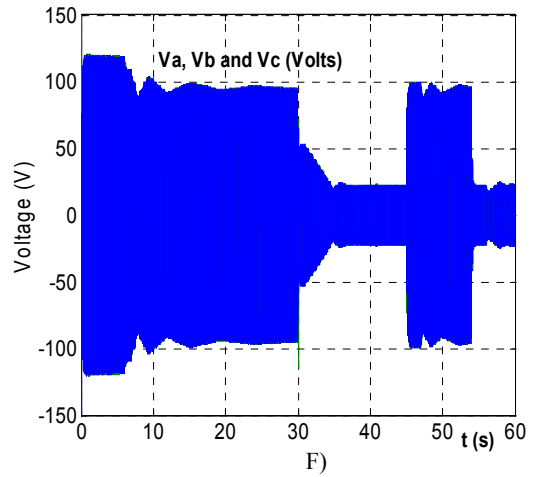
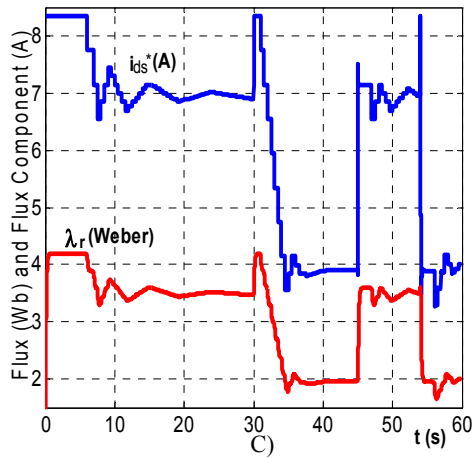
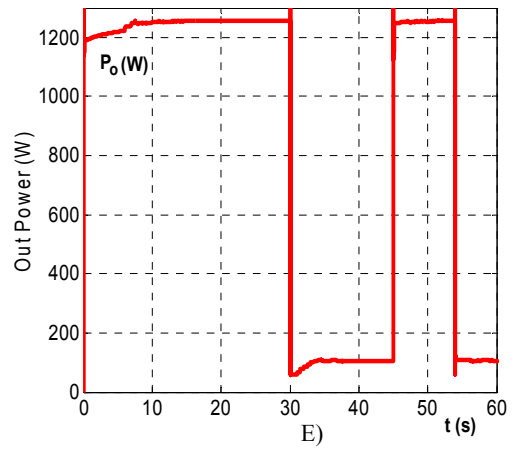
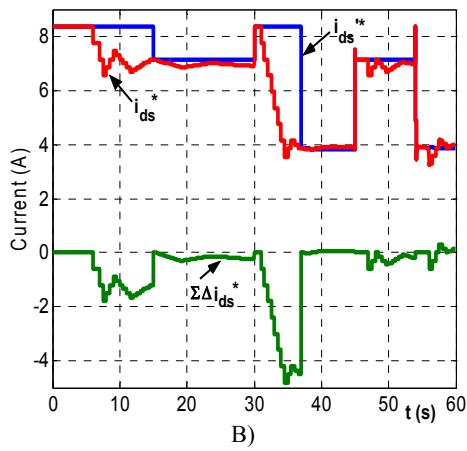
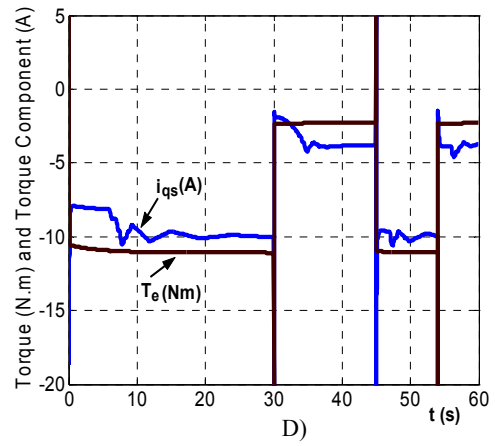
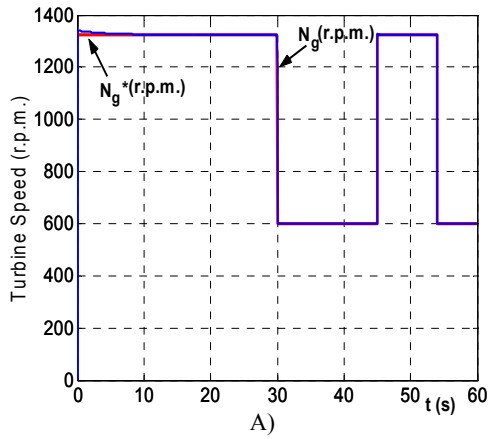

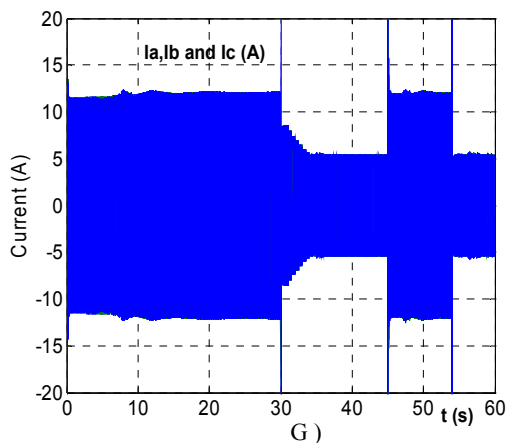

Figure 6: Results of simulation for operation of the fuzzy controller: A) Reference and actual speed on the axis of turbine in r.p.m.; B) Components of d -axis current; C) Components of d -axis current and rotor flux; D) Components of q -axis current and torque estimate; E) Out power; F) Voltage in the phases A, B and C; F) Current in the phases A, B and C.

4 CONCLUSIONS

The proposed control strategy consists of a more effective way to implement the efficiency optimization via flux control in an induction machine. From the analysis of literature can be observed that in the comparative study of the diverse known search techniques, none of them results on a process as fast as the one achieved with the present method. This implies a great energy save, because the system can be tuned all the time and operate at maximum efficiency. Another noteworthy point is that the transition from steady to transitory state occurs without abrupt changes in the system, or without any topological control change, since the displacement from a low torque point to one of higher torque or vice-versa is already programmed in the base of rules. The salient features of this technique are summarized next: i) It is applicable to any machine size, and does not require knowledge of machine parameters; ii) The rule base self tuning is progressive, and does not need any intervention from the operator; iii) Once tuned, the system is capable of operating all the time at optimum efficiency, without delay from one steady state condition to another, with significant energy saving; iv) During transients the rule base is kept active and, as a consequence there is no switching from one control strategy (for steady state) to another (during transients), provided that the tuning has been completed; v) Proper disturbance compensation is

included, such that no correction is needed to keep torque and speed constant during the optimization process; and vi) The system is capable of tracking slow parameter deviations, guaranteeing true optimum efficiency.

ACKNOWLEDGEMENTS

The authors wish to acknowledge the support of Fha – Foundation for the Development of New Technologies of Hydrogen in Aragón; CIRCE – Centre of Research for Energy Resources and Consumption; as well as CEFET-BA and University of Zaragoza.

REFERENCES

- Kumar, Vinod and Joshi, R. R. 2007. Fuzzy Logic Based Light Load Efficiency Improvement of Matrix Converter Based Wind Generator System. In *Journal of Theoretical and Applied Information Thecnology*, pp. 79 – 89. JATIT.
- Leidhold, Roberto, Garcia, Guillermo and Valla, Maria Inés. February 2002. Field-Oriented Controller Induction Generator With Loss Minimization. *Transactions on Industrial Electronics*. Vol. 49. No 1 pp. 147-156, February 2002. IEEE.
- Sousa, G. C. D. and B. K. Bose, (1995), Fuzzy logic based on-line efficiency optimization control of an indirect vector controlled induction motor drive, *Transactions on Industrial Electronics* vol. 42 n° 2, pp. 192-198. IEEE.
- Rüncos, F. at alli, Geração de Energia Eólica - *Tecnologias Atuais e Futuras*. WEG Jaraguá do Sul. Brasil. www.weg.com.br. WEG Máquinas S.A.
- Simões, Marcelo Godoy, Franceschetti, N. N. and BOSE, Bimal Kumar. 1999. Otimização de um Sistema de Geração de Energia Eólica Através de Controle Fuzzy. *SBA Controle & Automação*. Vol. No 01, pp. 48-58. Brasil. Jan., Fev., Mar., Abril de 1999. SBA.
- Sousa, G. C. D., Bose, B. K. and J. Cleland, (1992), “Loss Modeling of Converter Induction Machine System for Variable Speed Drive”, *Proceedings of the IECON'92, International Conference on Industrial Electronics, Control and Instrumentation*, vol. 1, pp. 114-120. IECON.
- F. Abrahamsen, Fred Blaabjerg, J. K. Pedersen, P. Z. Grabowski and P. Thogersen, (1998), On the Energy Optimized Control of Standard and High-Efficiency Induction Motors in CT and HVAC Applications, *Transactions on Industry Applications*, vol. 34, n° 4, pp. 822-831. IEEE.
- F. Abrahamsen, Fred Blaabjerg, J. K. Pedersen, (1996), State -of-the-Art of optimal Efficiency Control of Low Cost Induction Motor Drives, *Power Electronics and Motion Control*, vol. 2, pp. 163-170. PEMC'96.

- J. Moreno-Eguilaz, Miguel Cipolla, Juan Peracula, Paulo J. da Costa Branco, (1997), Induction Motor Optimum Flux Search Algorithms with Transient State Loss Minimization Using a Fuzzy Logic Based Supervisor, Power Electronics Specialists Conference, 28th, Annual IEEE, vol. 2, pp. 1302 – 1308.
- Souza, Durval de Almeida, Aragão Filho, W. C. P. and Sousa, G. C. D. August 2007. Adaptive Fuzzy Controller for Efficiency Optimization of Inductions Motors. *Transactions on Industrial Electronics, Vol 54, No 4, pp2157-2164*. IEEE.
- Leidhold, Roberto, Garcia, Guillermo and Valla, Maria Inés. 2002. Control para Máximo Rendimiento de Generadores Eólicos de Velocidad Variable, con Limitación de Velocidad y Potencia. *XVI Congresso Brasileiro de Automática. Natal, RN. 2 a 5 de Setembro de 2002.pp. 3121-3126*. CBA.
- Deprez, Wim et al. 2007. Energy Efficiency of Small Induction Machines: Comparison Between Motor and Generator Mode. *European Copper Institute. Vol. 3, pp 1-6.ISSUE 1. Digest of 11/01/2007*. Leonardo Energy.