

ANALYSIS OF REMS GTS ERRORS DUE TO MSL ROVER AND MARTIAN ENVIRONMENT

Eduardo Sebastián, Carlos Armiens and Javier Gomez-Elvira

*Lab. de Robótica y Exploración Planetaria, Centro de Astrobiología, Ctra. Ajalvir Km.4, Torrejón de Ardoz, Spain
sebastianme@inta.es*

Keywords: Environmental monitoring, infrared temperature detection and sensor error sources.

Abstract: This paper analyses the external sources of error of the REMS GTS, a contactless instrument to measure ground temperature that is part of the payload of the NASA MSL mission to Mars. Some environment properties such as atmosphere opacity, solar radiance, ground emissivity and rover IR emissions are studied, determining GTS characteristics. The article also proposes a simplified geometrical and thermal model of the rover and environment in order to evaluate and quantify their influence in ground temperature measurements. Finally, the article summarizes simulation results and provides solutions in order to improve sensor accuracy.

1 INTRODUCTION

The GTS (Ground Temperature Sensor), one of the REMS (Rover Environmental Monitoring Station) instruments, is mainly dedicated to measure the brightness temperature of Martian surface, using three thermopiles detectors in three infrared IR bands, and looking directly at the ground. The selected channels are 8-14 μm , 16-20 μm and 14.5-15.5 μm .

In general it can be said that two error sources are associated with contactless temperature measurements. On the one hand internal sources, all those related with the sensor, the amplifying electronics, and also errors associated with calibration and sensor degradation. On the other hand we have the errors due to the environment. In the case of the REMS GTS the environment shows difficulties because of the uncertainty in Martian surface emissivity, reflections from the rover and the Sun, and atmosphere absorbance.

The main objective of this paper is to justify the GTS design based on environment restrictions, as well as to obtain a thermal model of the rover and the environment in order to analyse and correct the errors in ground temperature determination.

The paper is organized as follows; section 2 introduces briefly the REMS GTS; section 3 describes the environmental sources of error, including a simplified radiation model of MSL

rover. Section 4 shows simulations to evaluate environment influence, using the proposed model. Finally, section 5 summarizes the results.

2 REMS GTS DESCRIPTION

REMS is an environmental station designed by the Centro de Astrobiología with the collaboration of national and international partners (CRISA/EADS, Universidad Politécnica de Cataluña (UPC) and Finish Meteorological Institute (FMI)), which is part of the payload of the MSL (Mars Science Laboratory) NASA mission to Mars, figure 1. This mission is expected to launch in the final months of 2009, and mainly consists of a rover with a complete set of scientific instruments.

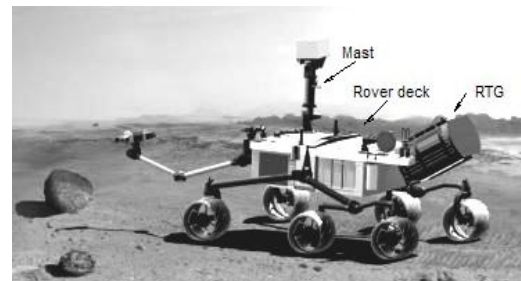

Figure 1: NASA MSL rover.

The rover main body hosts the electronics associated with the whole set of instruments, rover communications and control systems. Additionally, it includes the RTG (Radioactive Temperature Generator) which is the rover energy source. The RTG extra heat is used by rover thermal designers to warm the rover body in order to keep alive the electronics inside.

The GTS shall be mounted in one of the REMS booms, which is placed in the rover mast at 1.6m height and hosts the electronics dedicated to amplify the thermopiles signals. The GTS includes an in-flight calibration system without moving parts, whose main goal is to compensate the sensor degradation due to the deposition of dust over its window (Sebastián and Gomez-Elvira, 2007). To avoid local effects, the GTS focuses a large surface area of around 100²m, shown in figure 2, measuring the average temperature. This area is far enough from the rover as to minimize its influence.

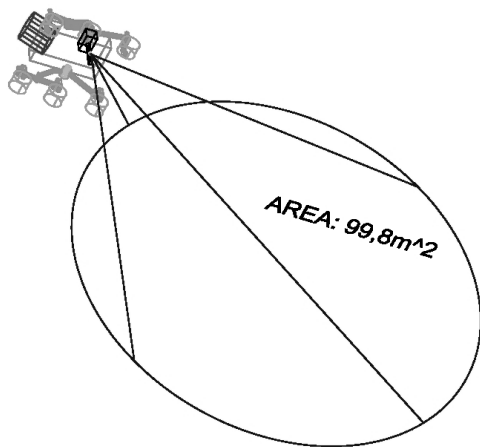

Figure 2: REMS GTS FOV and MSL rover simplified draft.

3 GTS ERRORS DUE TO MARTIAN ENVIRONMENT

Contactless temperature measurements are based on the integration of the IR radiation coming from a body. This radiation depends mainly on three factors: The temperature of the focused area, the emissivity ϵ of its surface, or what is the same the capacity of the body to emit IR energy, and finally the reflectivity r of its surface, that shows how the body reflects energy coming from the environment.

For the characteristic temperatures of Mars the emitted radiation falls mostly in the IR range. Following Wien's law, the maximum of the

blackbody spectral radiance for a given temperature is given by $\lambda_{max}[\mu\text{m}]=2898/T[\text{K}]$. If the maximal and minimal Martian temperatures are $T_{max}=293\text{K}$ and $T_{min}=150\text{K}$ then the sensor is designed to work optimally in the range from 9.9 μm to 19.3 μm .

3.1 Atmosphere Transmission Windows

The Martian atmosphere consists mostly of CO₂, which has a strongly absorbing band centred at 15 μm . The CO₂ in the column of air within the cone of view may also act as absorber and emitter (notice that the air is generally at a very different temperature from the ground) around the band. Additionally, water molecules have a very strong absorption at 1.45 μm , and a weak absorption at 6.27 μm (Martin, 1986).

3.2 Reflected Solar Radiance

Since the typical emissivities of Martian soils are different from one, the IR Solar radiation shall be added up to ground emissions (Lienhard and Lienhard, 2006). Assuming that in the IR the Sun radiance on the Martian surface is equal to the one on top (inside atmosphere transmission windows), and that the Martian ground IR reflectivity $r=1-\epsilon$, with ϵ the emissivity, is bounded to 0.1, one can obtain the reflected flux as $E_{reflected}=r \cdot E_{sun}$. The solar flux on Mars surface is, $F_{sun}=E \cdot (R_s/D)^2$ with $R_s=6.96 \times 10^8\text{m}$ the Sun radius, $D=1.52 \cdot 1\text{AU}=1.52 \cdot 1.5 \times 10^{12}\text{m}$ the Sun to Mars distance, and where E is the radiance of a blackbody emitting at a temperature $T=6000\text{K}$ (Vázquez *et al.*, 2005).

The measurements must be performed in a range where the ratio of IR radiance emitted by the Martian surface to the solar IR radiance reflected by the Martian surface is significantly greater than one. For instance, figure 3 shows that above 8 μm the solar reflected radiance is smaller than 0.5% for the lower ground temperature, $T_g=150\text{K}$.

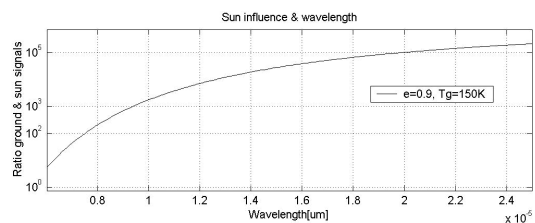

Figure 3: Ratio ground signal/sun radiance vs. wavelength.

Therefore, the GTS channels 8-14 μm and 16-20 μm are selected taking into account the optimum wavelength range from Wien's law, but trying to avoid the atmospheric absorption bands and the wavelengths in which solar radiation cannot be neglected. Each channel is specialised in the measure of a temperature range where the higher S/N ratio, based on the Planck's law, is achieved (Vázquez *et al.*, 2005). The other GTS band 14.5-15.5 μm shall measure the temperature of Martian atmosphere using for that the CO₂ emission band.

3.3 Reflected Rover Radiance

The MSL rover is a source of error for the GTS, since some parts of it are subjected to temperatures over the ground. These rover elements are mainly the RTG and the rover body, which can reach temperatures 200K and 50K over the atmosphere, respectively. These elements are painted using high emissivity paint, and their temperature shall be recorded on line during Martian operation.

In order to evaluate rover influence as a source of error in the determination of ground temperature it is necessary a thermal conduction and radiation model of Martian environment. In (Lee, 2006) the heating process of ground surface by thermal conduction due to the RTG is studied. The results show a neglected influence in the area focused by the GTS. On the other hand, figure 2 shows a simplified geometrical representation of the environment (GTS thermopiles, rover, atmosphere and Martian surface), from which rover radiance reflected on the ground can be estimated based on a radiation diagram. The radiation model considers that the IR energy reflected by the ground is completely diffuse.

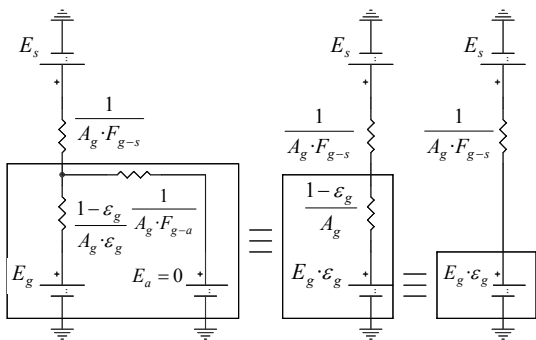

Figure 4: GTS and ground equivalent thermal circuit.

The first step in rover radiance influence analysis considers an ideal situation in which the rover does

not exist. The circuit shown in figure 4 represents an electrical analogy of the thermal model, in which voltage generators and currents are equivalent to the energy flux radiated by each body and the heat exchange respectively and resistors represent surface and geometry radiation resistances. The value of the resistors depends on parameters such as the areas and emissivities of the bodies, and the view factor between them (Lienhard and Lienhard, 2006). The atmosphere, as it was said before, is modelled as a transparent body that does not emit energy inside the measurement wavelengths, $E_a=0$. In this way, A_g represents the area of the ground seen by the GTS, ϵ_g the emissivity of the ground, $F_{x,y}$ the view factor between the bodies determined by the subscripts, and finally E_x represents the energy radiated by a blackbody at the temperature of the body determined by the subscript and inside the measurement band of the thermopile. The subscript g is for ground, a is for atmosphere and s is for the thermopiles. The expression of E_x follows Planck's law and takes the form,

$$E_x = \int T(\lambda) \cdot 2hc^2 / \lambda^5 \left(e^{hc/\lambda kT_x} - 1 \right) d\lambda [W/m^2] \quad (1)$$

where $T(\lambda)$ is the thermopiles filter transmittance.

Figure 4 shows two successive simplifications of the electrical circuit. The first one obtains an equivalent circuit, assuming that the view factor F_{g-a} is very close to the unit. This is reasonable because of the small size of the thermopile and environment geometry. The second simplification assumes two things: first the view factor F_{g-s} is very small and close to zero, since the area of the thermopile compared with the distance between the thermopile and the ground is very small. Second, ϵ_g takes real values that go from 0.9 to 1. Thus, the equivalent resistor is dominated by the value of the geometry resistance.

This circuit gives us means for calculating the heat exchange between the environment and the sensor, whose temperature (T_s) is known. From it, and based on GTS thermopiles sensibility $G_s[V/W]$, the output voltage of the thermopiles (2) can be obtained. This voltage shall be considered as the GTS ideal output, and shall be compared with the real one, once the rover is included in the thermal model. The result of this comparison shall be the error introduced by rover heated bodies. In addition to that, equation (2) depends on the value of ground emissivity, ϵ_g , which is an *a priori* unknown parameter that introduces also uncertainty in ground temperature determination.

$$V_{out} = G_S \cdot \Delta E \quad \Delta E = A_g \cdot F_{g-s} \cdot (\epsilon_g \cdot E_g - E_s) \quad (2)$$

The next step in rover influence analysis includes the rover geometrical and thermal model. Figure 5 starts from a previous simplification of rover body and RTG equivalent circuits. This simplification, whose objective is to obtain the equivalent circuit for these bodies and the atmosphere, is similar to the carried out in figure 4 for Martian ground.

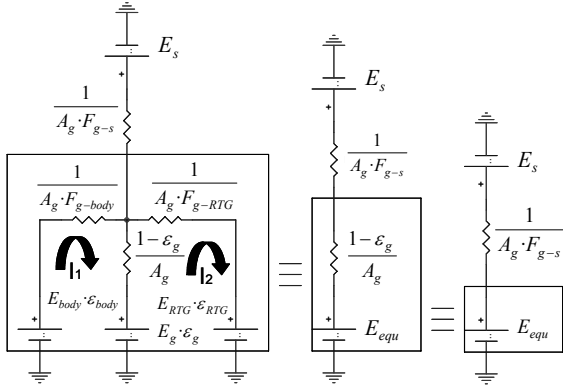

Figure 5: GTS, rover body and ground equivalent thermal circuit.

The equivalent resistance of the squared area of figure 5 can be easily calculated, assuming that view factors between ground and rover body (F_{g-body}) and ground and RTG (F_{g-RTG}) take values close to zero. Thus, the resistor inside the ground branch of the circuit is much smaller than the others, and its value dominates. Equally, the calculation of the equivalent generator of the squared area E_{equ} needs to solve the equations system (3) for I_1 and substitute its value in (4). And finally, the second simplification follows the same reasoning of figure 4.

$$\begin{bmatrix} E_g \cdot \epsilon_g - E_{RTG} \cdot \epsilon_{RTG} \\ E_{RTG} \cdot \epsilon_{RTG} - E_{body} \cdot \epsilon_{body} \end{bmatrix} = \begin{bmatrix} (1 - \epsilon_g) F_{g-RTG} + 1 & -1 \\ A_g \cdot F_{g-RTG} & A_g \cdot F_{g-RTG} \\ -1 & F_{g-RTG} + F_{g-body} \\ A_g \cdot F_{g-RTG} & A_g \cdot F_{g-RTG} \cdot F_{g-body} \end{bmatrix} \begin{bmatrix} I_1 \\ I_2 \end{bmatrix} \quad (3)$$

$$E_{equ} = -I_1 \cdot \frac{(1 - \epsilon_g)}{A_g} + E_g \cdot \epsilon_g \quad (4)$$

Newly, equation (4) shows a dependency of ground emissivity, ϵ_g . In this case temperatures, emissivities and view factors of rover body and RTG appear additionally in the equation as a new source of uncertainty.

4 SIMULATIONS ON ROVER AND EMISSIVITY INFLUENCE

The development of practical test with a real or scaled model of the MSL rover is extremely costly, since Martian temperature ranges requires the usage of complicate climatic chambers. From this point of view, this chapter is dedicated to develop preliminary simulations to evaluate or obtain a upper bound of rover and ground emissivity influence in the determination of Martian surface temperature.

The simulations are based on the GTS thermal radiation model described in the previous section. Then, to apply the model, the values of the view factors and the ground area covered by the sensor are required. In order to obtain practical data, simulations using the software package *Thermal Desktop* and a simplified geometrical model of the problem similar to the shown in figure 2, have been carried out. The model assumes that the rover and the ground are in a horizontal plane. The results are shown in table 1. Additionally, it must be pointed out that the value of the energy terms, E_x , are obtained based on thermopiles practical data (Sebastián and Gomez-Elvira, 2007).

Table 1: REMS GTS simulation data.

Body	ϵ	T	A	F_{g-x}
GTS	1	$T_g + 20K$	$1mm^2$	1.99×10^{-9}
Ground	0.91-0.99	T_g	$99.8m^2$	
Rover	0.8	$T_g + 70K$		0.0021
RTG	0.8	$T_g + 220K$		0.00101

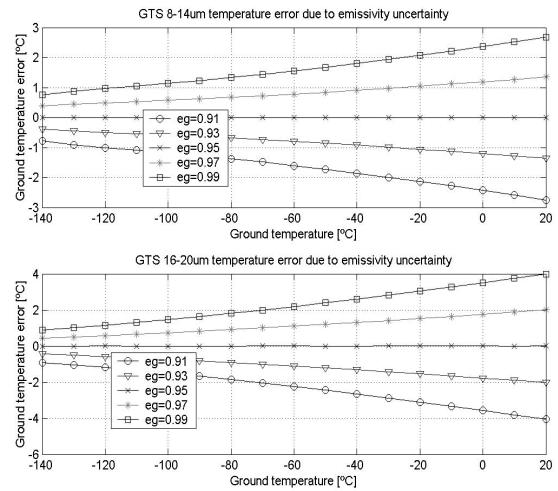

Figure 6: Ground temperature determination error due to ground emissivity uncertainty, supposing an emissivity value of 0.95.

The first simulation, figure 6, tries to analyse the error associated to the determination of ground temperature, generated by the uncertainty in ground emissivity without taking into account rover effects. Temperature error data are provided for the thermopiles 8-14 μ m and 16-20 μ m, considering an *a priori* value for ground emissivity of 0.95. The simulation is run for a possible range of Martian ground temperatures, from 133K to 293K.

The second simulation, figure 7, analyses the error introduced by rover body and the RTG. In this case, ground emissivity is assumed to be known.

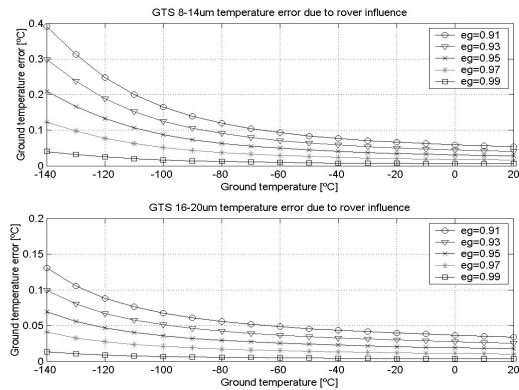

Figure 7: Ground temperature determination error due to rover influence, supposing known values for ground emissivities.

Finally, the last simulation, figure 8, includes the errors associated to ground emissivity uncertainty and rover body and RTG reflections, supposing a value for the ground emissivity of 0.95.

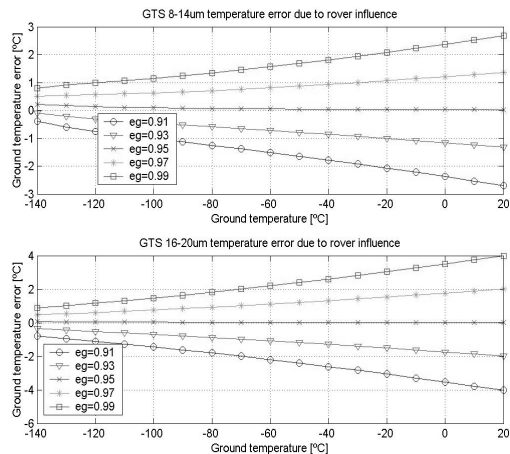

Figure 8: Ground temperature determination error due to rover influence and ground emissivity uncertainty, supposing an emissivity value of 0.95.

5 CONCLUSIONS AND FUTURE WORK

The selection of GTS measurement bands is conditioned by Martian atmosphere optical properties, ground temperatures as well as taking into account solar reflected radiance, in order to minimize or neglect the associated errors.

The REMS GTS location and orientation has been selected in order to minimize rover influence, due to the heating process of ground surface by thermal conduction and rover indirect view throughout ground reflected radiance. Additionally, GTS field of view has been maximized in order to increase signal to noise ratio, avoiding rover direct vision.

Simulations on ground emissivity uncertainty have shown an important error contribution in ground temperature determination, reaching error values of ± 4 K. This error is initially compliant with GTS instrument required accuracy of ± 5 K, nevertheless is so big that its contribution to the total error budget must be reduced.

A possible solution to deal with this error resorts to study the emissivity of similar soils to those found on Mars. MSL mission includes a set of payload instruments capable of providing detail information about Martian soils composition. Thus, after knowing the kind of soil in which the rover is operating, the studied emissivity value can be applied.

Colour pyrometry techniques (Joners and Gardner, 1980) are other possible solution, which could be implemented in order to estimate ground temperature and emissivity at the same time. A possible algorithm consists of four equations (5) with four unknown variables: the emissivities ϵ_g^{8-14} and ϵ_g^{16-20} , and ground temperatures T_{g1} and T_{g2} . The first two equations are obtained from the equation (2), particularized for the measurement bands (8-14 μ m, 16-20 μ m). To complete the four equations a new measurement for a different ground temperature is required, while rover remains still in order to assume constant the value of ground emissivity.

$$\begin{aligned} E_{equ}^{8-14, Tg1} &= f(T_{g1}, \epsilon_g^{8-14}) & E_{equ}^{16-20, Tg1} &= f(T_{g1}, \epsilon_g^{16-20}) \\ E_{equ}^{8-14, Tg2} &= f(T_{g2}, \epsilon_g^{8-14}) & E_{equ}^{16-20, Tg2} &= f(T_{g2}, \epsilon_g^{16-20}) \end{aligned} \quad (5)$$

The other source of error studied in this article, rover over temperature effect, generates temperature errors below ± 0.4 K, for the worst ground temperature conditions. Initially, this error could be neglected in comparison with others, and the

required GTS accuracy. However, this study assumes some simplifications on environment geometry and ground emissivity. For instance, frost formation over the ground or different ground tilts could modify rover reflectance, increasing error contribution.

Therefore, an algorithm to compensate rover influence could be required. The algorithm shall necessarily be based on the model described in section 3, subtracting in (4) the effect of the undesired energy rover terms and solving for E_g . In order to do it, an estimation of ϵ_g , A_g , F_{g-body} and F_{g-RTG} , and the real temperatures of rover bodies are required. The topography of the surface seen by the sensor modifies the view factors between the different environment objects. Thus, in order to carry out this geometrical analysis it is necessary to have a three-dimensional image of rover environment, as well as rover position and orientation. These data shall be provided by NASA. Afterwards, they shall be used to obtain more accurate view factors and areas, or just as a quality control system to confirm the validity of the results. For instance, CO₂ frost, shadows with different ground temperature, or extreme ground tilts are different circumstances to be detected.

A more rigorous analysis of rover influence and a possible improvement in this algorithm must include the sensibility of GTS versus the radiation incident angle. Initially, the whole surface area seen by the sensor is weighted equally, this is reasonable for ground emitted radiation since the whole ground is supposed to be at the same temperature. Nevertheless, several small differentials of area, in which the GTS sensibility is different, could be considered instead of a unique ground area. So, IR energy coming from the rover and reflected in these differentials of area must be weighted considering GTS sensibility. Equation 6 shows how the geometrical resistor between ground and RTG would be calculated,

$$\frac{1}{\sum g_i \cdot A_{gi} \cdot F_{g-RTGi}} \quad (6)$$

where A_{gi} is the differential of area i , F_{g-RTGi} is the view factor between the RTG and the differential of area i , and g_i is the weighting factor that considers GTS sensibility. Sensibility depends on the incident angle of the radiation and fulfils $A_g = \sum g_i \cdot A_{gi}$.

Finally, the simplify model described in this article must be confirmed using a specialized software such us *Thermal Desktop*, evaluating the

global behaviour of the model and not only for obtaining the value of the view factors.

ACKNOWLEDGEMENTS

The authors would like to express special thanks to all members of the REMS project who are collaborating in the development of the GTS.

REFERENCES

- Joners T.P. Gardner J.L. 1980. Multi-wavelength radiation pyrometry where reflectance is measured to estimate emissivity. *Phys. E: Sci. intrum.*, 1, 3006-319.
- Lienhard IV J.H. and Lienhard V. J.H. 2006. *A Heat Transfer Textbook*. web.mit.edu, 3rd edition.
- Lee C. J. 2006. *MSL study on RTG-to-Ground Interaction Zone*. Applied Sciences Laboratory, Inc. internal report.
- Martin T.Z. 1986. Thermal infrared Opacity Of The Mars Atmosphere. *Icarus*, 66, 2-21.
- Sebastián E. and Gomez-Elvira J. 2007. Preliminary tests of the REMS GT-sensor, In *ICINCO'07 International Conference on Informatics in Control, Automation and Robotics*, Angers (France).
- Vázquez L., Zorzano M.P., Fernández D., McEwan I. 2005. Considerations about the IR Ground Temperature Sensor. *CAB, REMS Technical Note*. Madrid.