

CONCEPTUAL DESIGN AND BREADBOARDING ACTIVITIES OF GEOSTATIONARY INTERFEROMETRIC MICROWAVE SOUNDER (GIMS)

Hao Liu, Ji Wu, Shengwei Zhang, Jingye Yan, Cheng Zhang, Weiyang Sun

Center for Space Science and Applied Research, Chinese Academy of Sciences,
P.O. Box 8701, Beijing, China, 100190

Phone: +86 10 6258 2778, Fax: +86 10 6252 8127, Email: liu_how@nmrs.ac.cn

1. INTRODUCTION

Realizing microwave atmosphere sounding from geostationary earth orbit (GEO) is an emerging researching field in recent years. GEO can guarantee the continuous observation, while microwave band can guarantee the all-weather observation with the 3D image ability on the atmosphere temperature and moisture in millimeter wave band. Those features make the GEO microwave observation very appealing for real time numeric meteorological forecasting.

The largest obstacle of GEO microwave observation is the restriction of spatial resolution. Using the oxygen band around 53GHz as an example, a quit large aperture antenna (approximately 5m) is needed to achieve a moderate spatial resolution (around 50km) in GEO. Launching, deploying and scanning such a large antenna aperture are difficult.

Interferometric aperture synthesis is a possible solution to this problem, by using a thinned antenna array to replace the single large aperture antenna [1][2]. Especially for the relative low sounding frequency (50~56GHz), aperture synthesis has now been deemed as the only practical approach to implement a space-borne instrument in GEO at the timeframe in 2015~2020.

In this paper, the authors will report some basic considerations on the synthetic aperture imaging radiometer for mm-wave sounding from GEO, especially for the China's next generation geostationary meteorological satellite (FY-4M).

2. GIMS CONCEPT OVERVIEW

The proposed instrument for FY-4M is named as GIMS (Geostationary Interferometric Microwave Sounder), which is operating at 50~56GHz for the purpose of atmospheric temperature sounding. GIMS is supposed to utilize a rotating circular thinned array, instead of a stationary Y-shape array, to reduce the required number of the antenna elements. Feasibility study of GIMS concept is now being conducted in CSSAR. System complexity of the future space-borne system is concerned at a high priority. Trade-off analysis had been initiated to approach a balance between the system performance (spatial resolution, radiometric sensitivity, aliasing free FOV and image refresh period) and the hardware budget (number of antenna/receiver units). The final scale definition of GIMS will be determined by the overall consideration on the application requirement satisfaction, technique risk reduction, and also the budget constrain. A minimum system definition with less than 30 antenna/receiver units has already been achieved according to the threshold system performance requirements proposed by application study:

- Spatial Resolution: 50 km
- Radiometric Accuracy: 1.5 K
- Image Refresh Period: 5 mins
- Field of View: 3000*3000 km

Fig. 1 illustrates the artistic view of GIMS instrument. An overall introduction of GIMS instrument will be given in this paper.

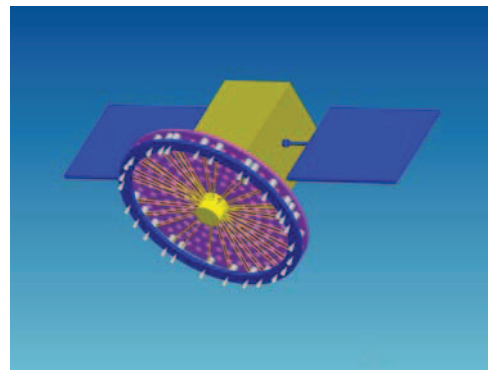

Fig. 1 GIMS Artistic View

3. BREADBORDING OF GIMS PROTOTYPE

A ground-based GIMS prototype with approximately 30 antenna/receiver units is now being developed in CSSAR for conceptual demonstration and technical evaluation. The prototype will operate 8 channels between 50~56GHz. Fig. 2 illustrates the block diagram of the prototype. The prototype will employ two-stage down conversion in the receiving chain. The first stage is in the front-end to realize SSB down conversion with high image rejection ratio. The second stage is in the IF module to realize IQ down conversion with selectable LO signals. The IF IQ signals will be distributedly sampled and transferred by optical fibres to the central correlation unit.

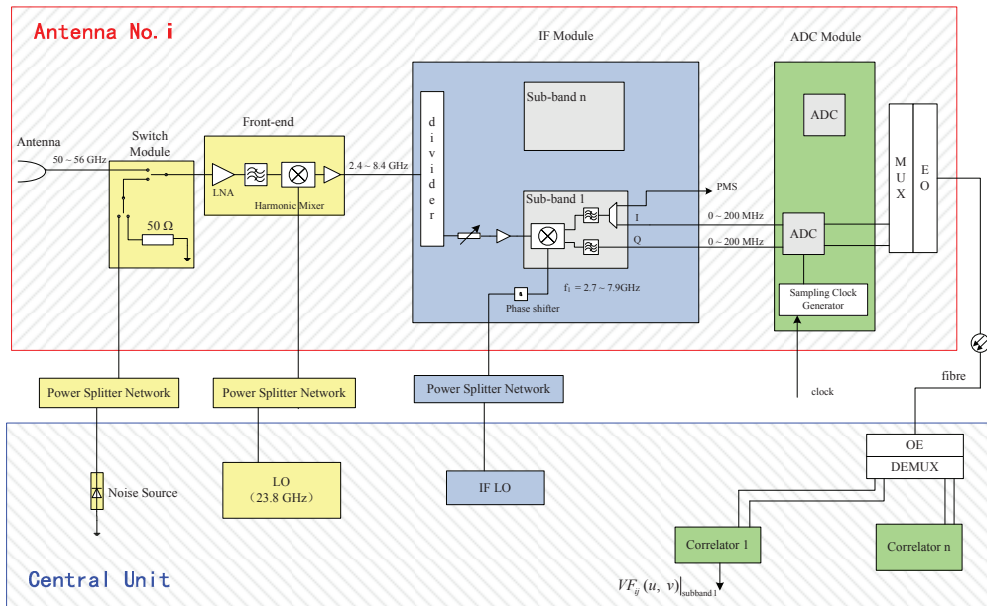
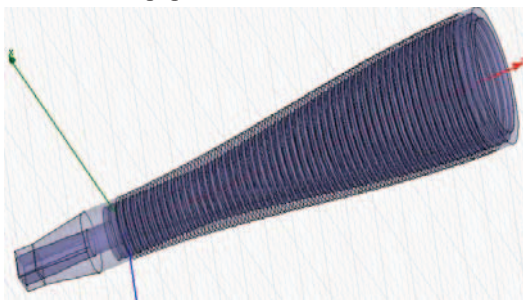
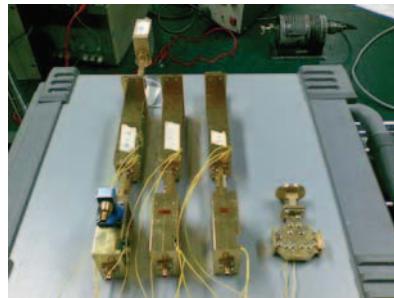

Fig. 2 GIMS Prototype System Configuration

The breadboarding of the GIMS prototype has been achieved by the development of a three-element interferometer. The breadboard antenna and front-ends are illustrated in Fig. 3. The test results of the breadboarding activities will also be introduced in this paper.



(a) Corrugated horn antenna design



(b) Front-end modules

Fig. 3 Hardware Breadboarding

4. REFERENCES

[1] Tanner, A. B.; Wilson, W. J.; Lambrigsten, B. H.; Dinardo, S. J.; Brown, S. T.; Kangaslahti, P. P.; Gaier, T. C.; Ruf, C. S.; Gross, S. M.; Lim, B. H.; Musko, S. B.; Rogacki, S.; Piepmeier, J. R., "Initial Results of the Geostationary Synthetic Thinned Array Radiometer (GeoSTAR) Demonstrator Instrument", IEEE Transactions on Geoscience and Remote Sensing, vol. 45, issue 7, pp. 1947-1957

[2] J. Christensen, A. Carlstrom, H. Ekstrom, A. Emrich, J. Embretsen, P. de Maagt, A. Colliander, "GAS: the Geostationary Atmospheric Sounder", Proceeding of IGARSS 2007.