

# Atmospheric Profiling Synthetic Observation System at THz Wave Band

Qijun Yao<sup>1,2</sup>, Dong Liu<sup>1,2</sup>, Zhenhui Lin<sup>1,2</sup>, Wenying Duan<sup>1,2</sup>, Jing Li<sup>1,2</sup>, Zheng Lou<sup>1,2</sup>, Shengcai Shi<sup>1,2</sup>, Hiroyuki Maezawa<sup>3</sup>, and Scott Paine<sup>4</sup>

<sup>1</sup>Purple Mountain Observatory, CAS, China

<sup>2</sup>Key Lab of Radio Astronomy, CAS, China

<sup>3</sup>Osaka Prefectural University, Japan

<sup>4</sup>Harvard-Smithsonian Center for Astrophysics, USA

**Abstract**—We introduced a dual-THz-band SIS (Superconductor- Insulator-Superconductor) heterodyne radiometer system which is under developing for the atmospheric profiling synthetic observation system project (APSOS). This THz system is intended to have a durable and compact design to meet the challenging requirements of remote operation at Tibetan Plateau. The system as well as its major components such as antenna tipping, quasi-optics, cryogenics, SIS mixers and FFTS backend will be discussed thoroughly. Some scientific simulation focusing on the atmospheric profiling components at THz bands will also be investigated.

## I. INTRODUCTION

Since 1990s, there have emerged a lot of radiometers working at millimeter and sub-millimeter wave bands to observe the atmosphere from space and ground [1][2]. As a part of the Atmospheric Profiling Synthetic Observation System (APSOS) project, a dual-band terahertz radiometer is proposed to monitor the vertical profiles of mesospheric water vapor and greenhouse gas over Yangbajing, Tibet. For weak greenhouse emission lines and long term observations, a radiometer equipped with high sensitive SIS receivers is well suitable for continuous atmospheric composition observation since it can work day and night which is otherwise impossible for optical methods. Our dual-band THz radiometer is optimized to operate at 200~300GHz and 400~500GHz for observing species such as H<sub>2</sub>O, O<sub>3</sub>, ClO, HCN, etc [3].

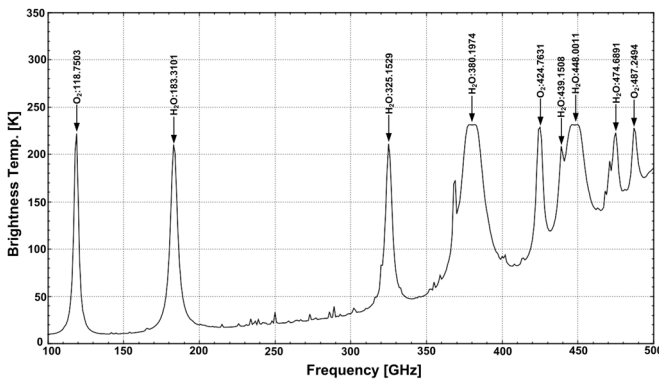

Fig. 1. Simulated atmosphere spectra (Tibet winter season) with AM 7.0[4]

## II. SYSTEM DESIGN

The radiometer system is to be designed as a standard container module for easy transportation and maintenance. The whole system can be divided into two major parts :the outdoor roof-top tipping unit and the indoor receiver(see Fig.2). The tipping unit mainly includes a flat tipping mirror, 300mm off-axis main reflector, sub-reflector, beam splitter, hot and

cold calibrators. The beam splitter splits the incoming signal into two polarized beams, which then couple to two sub-band SIS receivers respectively to cover a wide frequency range with a single antenna. To make the indoor instruments work smoothly in as long a period as a whole year, a thermal control system is adopted to utilize the massive heat dissipated by the helium compressor in winter and to control the container ventilation in summer.

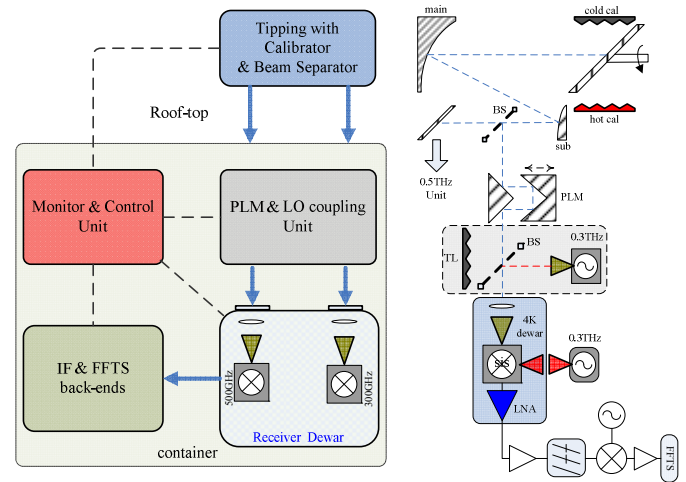

Fig. 2. The radiometer system (left) and its lower band details (right)

### A. The Quasi-Optics

The main antenna is a small Cassegrain system. A 300mm aperture size is chosen to achieve a resolution better than 1km at 80km above ground and to get a better angle resolution while tipping. In order to make the main reflector compact and to realize an easy optical arrangement, a 30 degree off-axis parabolic mirror with PFL around 550mm is used. With the sub-reflector tiled at a small angle, the reflected signal propagates in the horizontal direction. After it hits the beam splitter (polarizer), each of the two polarized beams folds back in the vertical direction to pass through the PLM&LO module, and then reaches the elliptic mirror inside the receiver Dewar and finally matches the feed horn of the corresponding SIS mixer.

### B. The Receiver

Compared to room-temperature Schottky receivers, SIS receivers have much high sensitivity and require less LO pumping power in the THz frequency regime [5]. This will make it realistic to observe milli-Kelvin level greenhouse species lines immersed in the noisy background. Parallel connected twin junctions (PCTJ) [6] are adopted in our SIS

mixer design. Simulated mixers noise temperature for the 200-300GHz band is lower than 40K with a -3dB~0dB conversion gain.

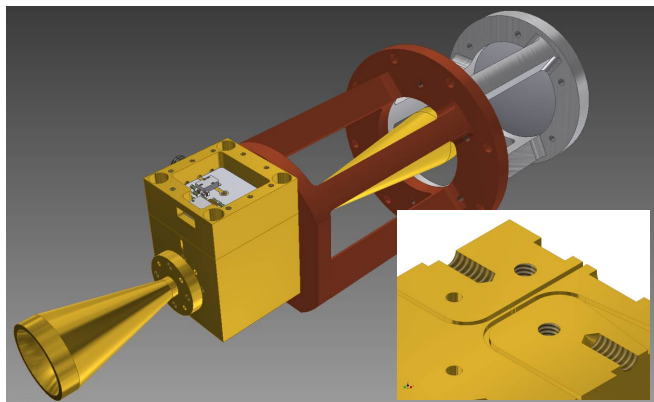

Fig. 3. 3D assembling model of the sis mixer block with diagonal feed horn

As shown in Fig. 3, the SIS mixer chip will be installed in a waveguide mount. The RF and LO signals are fed by different horns and coupled through a directional coupler. The cryogenic Dewar driven by a two-stage GM close-cycled cryocooler is designed to accommodate the two SIS mixers and following low noise cryogenic IF amplifiers [7]. To achieve low power consumption and good mobility, high thermo-isolation and low thermo-load are kept in mind throughout the design.

### C. The Back-End

The dual-band THz radiometer is configured as a standard heterodyne receiver. The IF signal coming from the SIS mixer and LNA is further amplified and converted to baseband, then processed by a spectrum analyzer. Compared to traditional spectra analyzers such as AOS or filter banks, FFTs (Fast Fourier Transform Spectrometer) based on high speed AD converters and high performance FPGA devices have more advantages. It is compact in size and more stable in long time integration. The experiment board based on E2V high speed ADC and Virtex6 FPGA has been verified on PCI express card and a new standalone version which does not need a host computer bus and is communicated through Ethernet has also been developed.

IF data from ADC is rearranged and spitted into 16 ways, thus reduce the data flow rate from 4Gbps (2GHz BW mode) to 250Mbps that matches the FPGA bus speed. In each way, they are further divided into 6 pipelines to do the butterfly operation in parallel. The calculated data is then fed into afterward data rearrangement and power spectrum section to retrieve the full 32k-point spectrum data. In order to realize a continuous spectrum analyzing, a ping-pong output buffer is also implemented on the FPGA chip.

### D. The Control Unit

The control unit is based on distributed controllers and internet, just as illustrated on Fig. 4. All the instruments except the GM cryocooler are centralized on two major control subunits: the roof top subunit and on-Dewar subunit according to their locations and functions. The main computer manages those instruments through CAN bus and team up the FFTs and data server through gigabit Ethernet. The observed data which store

on the data server will be dumped at fixed interval and preprocessed by onsite observation team. The hardware to be used as controllers is a rugged PXI board and ARM based MCU for easy software development. The main computer and data server will run on Linux and be capable of doing remote administration on it over internet.

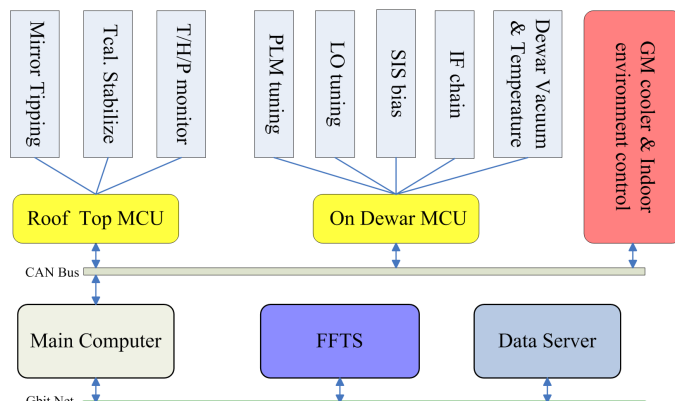

Fig. 4. The overall control and data acquisition system for the dual-band THz radiometer.

## III. SUMMARY

We have designed a dual-band SIS heterodyne radiometer in THz band for the atmospheric profiling synthetic observation system (APSOS) project. With reliability and mobility in mind, the whole system is divided into modules and the control system built on a distributed architecture. Interfaces between modules are defined in simple and clear ways for easy maintenance. Heat dissipated from the instruments is also utilized to maintain the indoor environment. The dual-band THz radiometer will be deployed to Yangbajing, Tibet for atmosphere observation in 2016.

## REFERENCES

- [1]. Ochiai Satoshi, "NICT millimeter-wave radiometer at Eureka," [http://smiles.nict.go.jp/mm\\_ram/eureka/](http://smiles.nict.go.jp/mm_ram/eureka/)
- [2]. Tomoo Nagahama, Hideaki Nakane, Yasumi Fujinuma, Mariko Ninomiya, Hideo Ogawa and Yasuo Fukui, "Ground-based millimeter-wave observations of ozone in the upper stratosphere and mesosphere over Tsukuba," Proc. Earth Planets Space, 51, 1287-1296, (1999).
- [3]. Nicola Schneider, Joachim Urban, Philippe Baron, "Potential of Radio Telescopes for Atmospheric Line Observations: 1. Observation Principles and Transmission Curves for Selected Sites," arXiv:0902.1642[astro-ph.EP], 6 Jul 2009.
- [4]. Scott Paine, "The AM atmospheric model," <http://www.cfa.harvard.edu/~spaine/am>
- [5]. P. H. Siegel, "THz technology," IEEE Transactions on Microwave Theory and Technology, Volume 50, 2002, pp. 910-928.
- [6]. S.C. Shi, T. Noguchi, and J. Inatani, "A new type of SIS mixer using parallel-connected twin junctions," in Conf. Dig. 19th Int. Conf. on IR and MM waves, K. Sakai and T. Yoneyama, Eds. Sendai, Japan, 1994, pp. 110-111.
- [7]. Qi-Jun Yao, Xue-Song Cao, Xu-Guo Zhang, Jing Li, Sheng-Cai Shi and Ji Yang, "A Compact 500GHz SIS Receiver System for POST," Proc. APMC2009, 551-554(2009).
- [8]. M. Tarengi, "The Atacama large millimeter/submillimeter array: overview & status," Astrophysics and Space Science, Volume 313, 2008, pp. 1-7.